

INSTALLATION INSTRUCTIONS 2916P Keypad

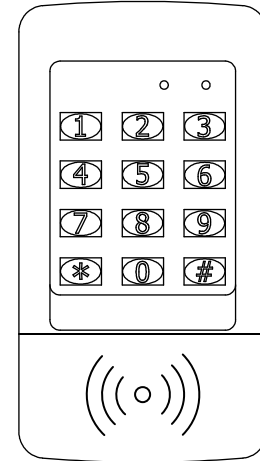

The *2916P Keypad Indoor/Outdoor Keypad* is a surface-mount digital keyless entry system designed for access control applications. The backlit keys are bright and easy-to-read. A heavy cast vandal resistant housing design with mounting plate allows the 2916P to be mounted on a rugged surface or on a standard single-gang electrical box.

The 2916P has a capacity of 500 users. Users can be assigned to use 4 to 6 digit PIN codes and/or HID 125kHz proximity access credentials. An authenticated access can be programmed to activate one or both of the relay outputs.

The timed “anti-passback” feature prevents using the same credentials twice before a programmed waiting period has elapsed.

Two long lasting solid state LED indicators show the status of the system. The left bi-color indicator lights red to indicate power, then green when a relay is active (access grant, etc.). The right indicator flashes yellow to indicate that the keypad is in programming mode.

An internal sounder can be programmed to beep each time a key is pressed or when an output is activated. An internal jumper sets the sounder volume high or low.

The **SENSE** input can be configured two ways through programming. When configured for “Door Sense”, the input is wired to a normally closed door position switch to detect when the door is opened or closed. Forced entry or door ajar situations can then be detected. The “Auto-relock” feature can also be used to turn off the Main Relay output immediately when the door is closed after access has been granted to prevent “tailgating”. When the **SENSE** input is configured for “Inhibit”, the input can be wired to a normally open “service” switch or automatic timer that will disable access while the switch is closed.

The **REQUEST-TO-EXIT** input can be wired to a normally open pushbutton to provide codeless activation of the Main Relay, Auxiliary Relay, Output #3 or Output #4 (programmable).

The **ALARM SHUNT** signal is available when access is granted. This signal can be programmed to activate any of the relays or solid state outputs to shunt alarm contacts on the access door/gate preventing the triggering of an alarm when an authorized access occurs.

The 2916P is powered from a 12 or 24V AC or DC source. The non-volatile EEPROM memory retains entry codes and programming when power is removed. An internal jumper is provided to reset the master code. The Main Relay has a 5 Amp capacity. The Auxiliary Relay has a 2 Amp capacity. Two solid state outputs, capable of sinking 100 mA to common are programmable for alarm shunting, or to signal forced entry, door ajar, keypad lockout, request-to-exit, and keypad active conditions.

Features

- Keypad programmable
- 500 user codes
- 3 User Modes
 - PIN or Card
 - Card Only
 - Card and PIN
- 4 to 6 digit user codes
- 4 independent outputs
- 4 independent timers
- 2 Form C relay contacts
- 2 solid state open collector outputs
- Program entry codes to activate one or two relays
- Disable input
- Door sense input
- Request-to-exit/Reception input
- Keypad tamper lockout
- Timed anti-passback
- Anti-tailgate
- Two LED status indicators
- Tactile key feel
- Audible code entry verification
- 12V or 24V, AC or DC operation

SPECIFICATIONS

Mechanical

Dimensions: 3.00" W x 5.75" H x 1.375" D
(1.4375" wall projection)

Electrical

Input Voltage: 12/24 Volts AC or DC
Operating Current: 30 mA typical, 150 mA max

Output Ratings

Main Relay: Form “C” 5 Amps @ 28 Volts max
Auxiliary Relay: Form “C” 2 Amp @ 28 Volts max
Type: Solid state outputs (Outputs #3 & #4)
Short-to-common 100 mA @ 24 VDC maximum

Environmental

Temperature: -4°F to 140°F (-20°C to 60°C)
Humidity: 5% to 95% non-condensing

QuickStart Programming

You must first enter programming mode to perform any function. The yellow indicator will blink slowly showing that the 2916P is in programming mode. Use the option codes to program each function. After the new data entry is complete for each function, the yellow indicator will flash quickly while the data is being stored and the green indicator will light briefly if the programming has been accepted. The red indicator will light if any programming data is entered incorrectly or the function is rejected. If a red indicator is seen, the entire function (option code + data) will have to be fully re-entered. The keypad will remain in programming mode until ** # is pressed or after 30 seconds of inactivity.

Set default parameters (first time use)

- Step 1. Enter: **#9# 123456#** Enter programming mode (default master code=123456)
- Step 2. Enter: **03# 4#** Set the entry code length to 4 digits
- Step 3. Enter: **21# 5#** Set the main relay activation time for 5 sec.
- Step 4. Enter: **** #** Exit programming mode

Assign a user (Card only)

- Step 1. Enter: **#9# 123456#** Enter programming mode (default master code)
- Step 2. Enter: **06# 002# 9876# 9876# 1# (Present card)** Assign card to User 002 with a PIN code of '9876'. Activate the main relay when validated.
- Step 3. Repeat Step 2 to enter another unique user & card, or continue to Step 4.
- Step 4. Enter: **** #** Exit programming mode.

Assign a user (PIN only)

- Step 1. Enter: **#9# 123456#** Enter programming mode (default master code)
- Step 2. Enter: **01# 003# 2580# 2580# 1#** Assign User 003 with a PIN code of '2580'. Activate the main relay when entered.
- Step 3. Repeat Step 2 to enter another unique user & PIN or continue to Step 4.
- Step 4. Enter: **** #** Exit programming mode

Test your new user

Present your card or enter an authorized PIN code + #. The green indicator should illuminate and the main relay should activate, unlocking the door for 5 seconds.

Deleting a user code

- Step 1. Enter: **#9# 123456#** Enter programming mode (default master code)
- Step 2. Enter: **02# 002# 002#** User 002 has been deleted.
- Step 3. Enter: **** #** Exit programming mode

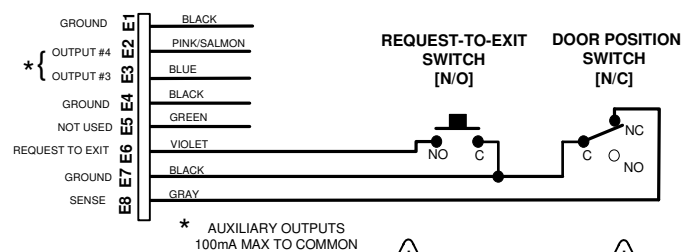
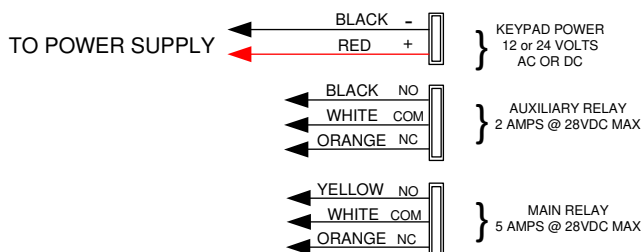
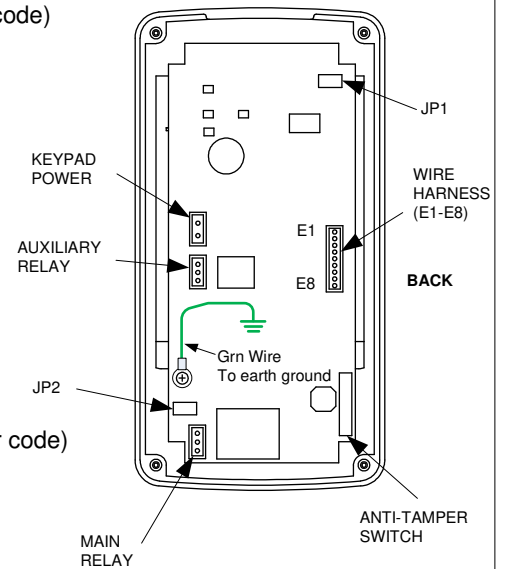
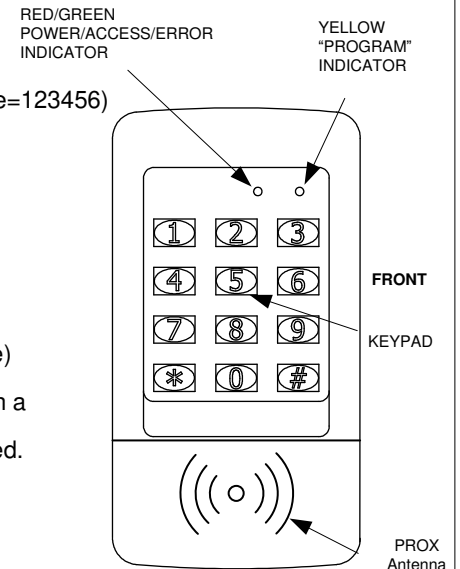

Fig. 2 Wiring Pigtail Color Code

CAUTION

IF THE UNIT IS AC POWERED, MAKE SURE THAT THE SECONDARY OF THE SYSTEM IS ISOLATED FROM EARTH GROUND

KEYPAD WIRING

See Fig. 3 for an example of a basic door installation. The keypad is mounted adjacent to the door. An electric door strike is mounted in the door jamb to release the door lock. A door contact switch is mounted on top of the door jamb for detecting when the door is open.

Use the following steps to wire the keypad. Refer to the wiring diagram shown in Fig. 4 to assist in the wiring.

Note: For lock power, use 18 AWG wire or larger (depending on load). Use 22 AWG or larger for signal connections. Refer to lock manufacturer's documentation for lock power requirements.

Output Connection

Install a low-voltage fail-secure electric door strike at the door to be controlled. Route 2 wires from the door strike to the keypad. Connect an MOV across the coil wires of the strike. Connect the (+) door strike wire to the keypad's MAIN RELAY N.O wire (yellow). Connect the other door strike wire to the keypad's PWR(-) wire (black). Connect the keypad's MAIN RELAY COM wire (white) to the keypad's PWR(+) wire (red).

Power Connection

Connect the power supply's output terminals to the keypad's PWR(+) wire (red) and PWR(-) wire (black). If using a DC supply, observe wiring polarity. If an AC transformer is being used, polarity does not matter.

Caution: If the unit is AC powered, make sure the secondary of the system transformer is isolated from earth ground.

Earth Ground

To avoid damage to the unit from static discharges, this unit must be connected to a proper earth ground. Connect the green earth ground wire to a good earth grounding point. Suggested wiring size is 18 AWG for earth ground.

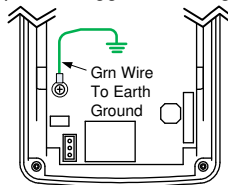

Sense Input

RE Note: The SENSE input (gray wire) can be programmed as either a door sense or inhibit input. Both features cannot be used at the same time. If you are not using the sense input, program this input for inhibit.

Door Sense: (Detect forced entry or door ajar conditions) Install a normally closed door switch on the door and route two wires from the switch to the keypad. Connect the door switch to the keypad's SENSE wire (gray/ E8) and COM wire (any black wire).

Inhibit: (Disable access) If an inhibit switch or timer is going to be used for temporarily disabling the keypad, route two wires from the switch or timer to the keypad. Connect the inhibit switch/timer's normally open contacts to the keypad's SENSE (gray/ E8) and COM (black wires) terminal.

Request-to-Exit Input (wiring shown on page 3, fig. 4)

If a request-to-exit pushbutton is going to be used, route two wires from the keypad box to a normally open pushbutton mounted on the secure side of the door. Connect the wires to the pushbutton and to the keypad's REX wire (violet/ E6) and COM (black wires) terminals.

Solid State Outputs

The two solid state outputs (Outputs #3 & #4) can be programmed to activate during various conditions. These "open collector" outputs can be used to activate indicators or sounders. See fig. 5 for wiring examples using the solid state outputs.

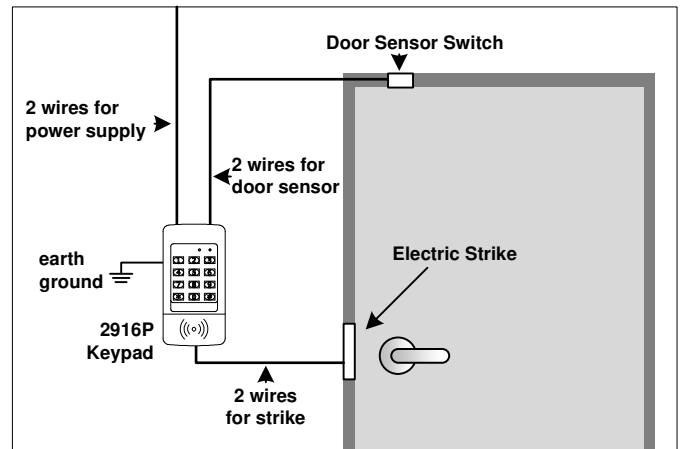

Fig. 3 Basic Door Installation

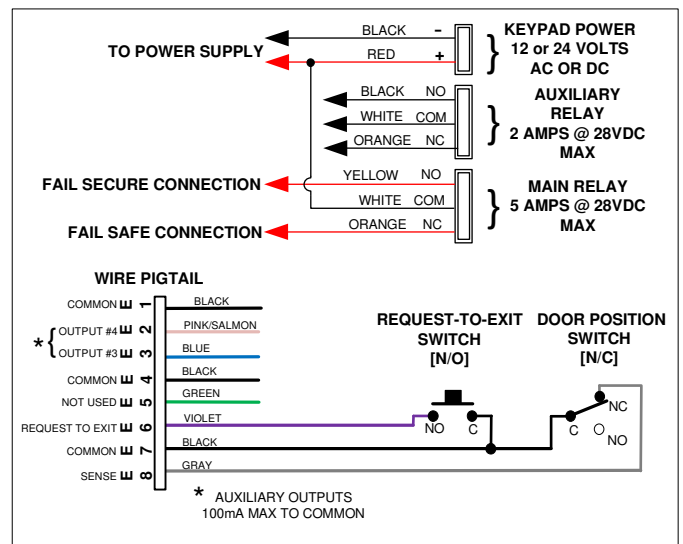

Fig. 4 Basic Door Installation Wiring

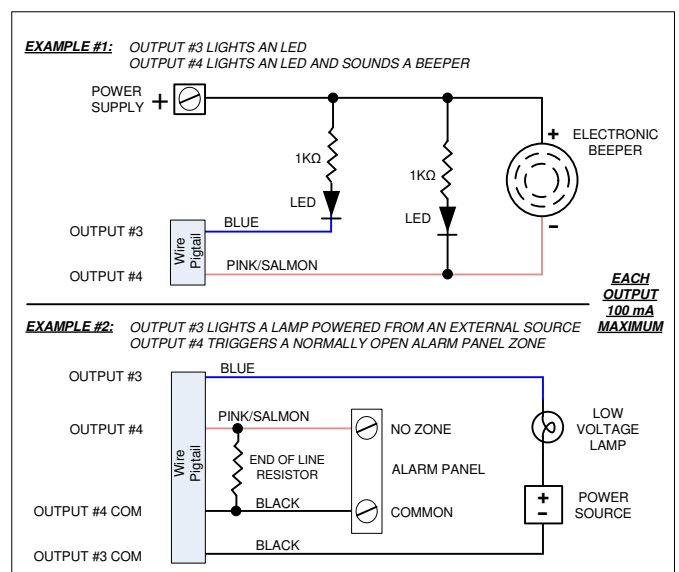

Fig. 5 Using Solid State Outputs

FACTORY DEFAULTS

Master Programming Code.....	123456
Entry Code Length.....	4 digits
Entry Mode.....	Card or PIN
Request-to-exit Output Relay.....	No Output
Alarm Shunt Output.....	Disabled
Forced Entry Output.....	No Output
Door Ajar Output.....	No Output
Main Relay On Time.....	.02 Seconds
Auxiliary Relay On Time.....	.02 Seconds
Solid State Output #3 On Time.....	.02 Seconds
Solid State Output #4 On Time.....	.02 Seconds
Door Sense/Inhibit Input.....	Door Sense
Keypad Lockout Output.....	Disabled
Keypad Active Output.....	Disabled
Beeper Sounds When Key Pressed.....	Yes
Beeper Sounds During Relay #1.....	No
Beeper Sounds During Relay #2.....	No
Beeper Sounds During Output #3.....	No
Beeper Sounds During Output #4.....	No
Keypad Lockout Count.....	3 Tries Before Lockout
Anti-Passback Time.....	No Anti-Passback
Auto-Relock.....	On

BASIC PROGRAMMING

When the 2916P is in Programming Mode the yellow indicator will blink slowly. After a programming command is selected, the yellow indicator will flash rapidly while the keypad is waiting for user input data. The green indicator will light if the data is accepted. The red indicator will light if any programming data is entered incorrectly, and the command will have to be fully re-entered. **IMPORTANT!** Cards & Codes are stored by User #. It is imperative that the User numbers and their assigned personnel are managed in the event a specific user ever needs to be deleted.

Entering Programming Mode

The 6-digit Master Programming Code (default = 123456) is used to enter Programming Mode.

Press: # 9 # Master Code #

Master Code = the current 6-digit Master Programming Code

Exiting Programming Mode

Press: ** #

The red indicator will light after exiting Programming Mode

Note: The 2916P will automatically exit Programming Mode after 30 seconds of inactivity

Re-entering a Command After a Mistake

If the red indicator lights, signaling an incorrect entry, or an incorrect key is pressed during programming, to clear the keypad and re-enter the command:

Press: * 9 #

Setting Entry Code Length

Default: 4 digits

Press: 03 # Length #

Length = 1-6 for entry code length

Note: If the Entry Code Length is going to be changed from the factory default of 4 digits, make this change first before programming any entry codes.

Select Entry Mode

Default: Card or PIN

Sets the entry mode for the 2916P.

Press: 05 # Mode #

Mode=Operating Mode(1-3)

1=Card or PIN; 2=Card Only 3=Card and PIN

Adding a New User

User PIN Only Access (No Card)

Press: 01 # User # Code # Code # Relay #

--- Or ---

User Card and or PIN Access

Press: 06 # User # Code # Code # Relay # Present Card

User=3-digit User number to be added: 001-500

Code=The new entry code: 1-999999, depending on code length

Relay=Relay output entry code will activate:

1=Main Relay 2=Auxiliary Relay 3=Both Relays

10=Relay #1, toggled 20=Relay #2, toggled 30=both Relays toggled

12=Relay #1 toggled; Relay #2 timed open

21=Relay #1 timed open; Relay #2 toggled

The yellow indicator will flash quickly while the 2916P stores the new user information in memory. The green indicator will light when the new code and card are accepted. If the user number already exists or an entry error has been made, the red indicator will light. Delete the user and re-enter the new information again.

Note: Leading zeros (zeros before the code number, i.e.0001) do not need to be entered when programming a new code. The 2916P will internally add any zeros to fill digits determined by the entry code length setting. Leading zeros will have to be entered by the user when entering their code to gain access.

Output Toggle Mode

When an output is programmed for Toggle Mode, the output alternates from OFF to ON or from ON to OFF each time it is accessed. When an output is toggled on, the green LED remains solid until toggled off.

The rules for a toggle output are:

- If the output is OFF, it will turn ON and stay on until the next activation.
- If the output is ON, it will turn OFF and stay off until the next activation.
- An authorized PIN, Card, or REX input programmed to momentarily activate that same relay will reset the relay to its normal state.

Adding Multiple Sequential Cards

Press: 08 # 1st User # Code # Code # Relay # Number of

users # Present 1st card

1st User =Starting user number to add

Number of users = Total number of consecutive cards to add

After presenting the 1st card, the green indicator will light as cards are added. NOTE: The "Code" will be the same for all users, but may be changed for each user using Function 04 below.

Adding Multiple Non-Sequential Cards

Press: 07 # 1st User # Code # Code # Relay # Number of users

Present 1st card, Present 2nd card, ..., Present last card

1st User =Starting user number to add

Number of users = Total number of consecutive cards to add

<p>Changing a User PIN</p> <p>Press: 04 # User # New Code # New Code # <i>User =The user number whose PIN will be changed</i></p>	<p>Select Door Ajar Output Default: No Output</p> <p>Sets which output activates if the DOOR SENSE input stays open 60 seconds after access is granted (door ajar time is adjustable using Function 25). This output is not timed.</p> <p>Press: 12 # Output # <i>Output=Output to Activate (0-4)</i> <i>1=Main Relay; 2=Auxiliary Relay; 3=Output #3; 4=Output #4;</i> <i>0=No Output</i></p>
<p>See the following example that sets entry codes 1234 for normal operation and 5678 for toggle operation.</p> <p>Press: 01 # User # 1 2 3 4 # 1 2 3 4 # 1 # <i>01=Programming Step; 1234=Entry Code; 1=Main Relay</i></p> <p>Press: 01 # User # 5 6 7 8 # 5 6 7 8 # 20 # <i>01=Program Step; 5678=Entry Code; 20=Auxiliary Relay toggle</i></p>	<p>Select Keypad Lockout Output Default: No Output</p> <p>Sets which output activates when the keypad is "locked out" after too many incorrect entry code attempts. The lockout time is 60 seconds.</p> <p>Press: 13 # Output # <i>Output=Output to Activate (0-4)</i> <i>1=Main Relay; 2 = Auxiliary Relay; 3=Output #3; 4=Output #4;</i> <i>0=No Output / Lockout Disable</i></p>
<p>Erasing a Single User</p> <p>Press: 02 # User # User # <i>User =The user number to delete 001-500</i></p> <p>The yellow indicator will flash quickly while the 2916P erases the user from memory. The green indicator will light when the code is erased.</p>	<p>Select Keypad Active Output Default: No Output</p> <p>Sets which output activates when any keys are pressed. This output is timed. If toggle mode is selected for the output, the timer value defaults to 2 seconds.</p> <p>Press: 14 # Output # <i>Output=Output to Activate(0-4)</i> <i>1=Main Relay; 2=Auxiliary Relay; 3=Output #3; 4=Output #4;</i> <i>0=No Output</i></p>
<p>Erasing Multiple Users (Sequential)</p> <p>Press: 09 # 1st User # Number of users # <i>1st User =Starting user number to delete</i> <i>Number of users = Total number of consecutive users to delete</i></p> <p>The yellow indicator will flash quickly while the 2916P erases the user from memory. The green indicator will light when the code is erased.</p>	<p>Select Alarm Shunt Output Default: No Output</p> <p>Sets which output activates during the time access is granted. (Use this output ot shunt alarm contacts attached to the access door.) This output may be timed or toggled.</p> <p>Press: 15 # Output # <i>Output=Output to Activate(0-4)</i> <i>1=Main Relay; 2=Auxiliary Relay; 3=Output #3; 4=Output #4;</i> <i>0=No Output</i></p>
<p>Erasing All Entry Codes</p> <p>WARNING: PERFORMING THIS COMMAND WILL REMOVE ALL ENTRY CODES FROM THE MEMORY</p> <p>Press: 97 # 0 0 0 0 0 0 # 0 0 0 0 0 0 #</p> <p>Note: The green indicator will light while the memory is being erased. This may take up to 15 seconds.</p>	<p>Select Request-to-Exit Output Default: No Output</p> <p>Sets which output activates when the Request-to-Exit input is grounded. This output may be timed or toggled.</p> <p>Press: 16 # Output # <i>Output=Output to Activate(0-4)</i> <i>1=Main Relay; 2=Auxiliary Relay; 3=Output #3; 4=Output #4;</i> <i>0=No Output</i></p> <p>REX input terminates toggle of Main or Aux. Relay</p>
<p>Configure Sense Input Default: INHIBIT</p> <p>The Sense Input (gray wire) can be programmed for either DOOR SENSE or INHIBIT.</p> <p>Press: 10 # Input # <i>Input=0 for Door Sense; =1 for Inhibit</i></p> <p>When programmed for DOOR SENSE, if an open condition on the input occurs <u>before</u> access is granted (with an entry code or with the request-to-enter input) a FORCED ENTRY output will occur. If an open condition remains 60 seconds <u>after</u> a relay activation for access, a DOOR AJAR output will occur.</p> <p>When programmed for INHIBIT, a closed condition on the input will prevent Relay #1 from activating when access is requested with an entry code. This mode is typically used with an external timer to disable the access device at certain times.</p>	<p>Anti-Tamper Output Default: No Output</p> <p>Sets which output activates when the Anti Tamper switch on the back of the keypad is activated.</p> <p>Press: 17 # Output # <i>Output=Output to Activate(0-4)</i> <i>0=No Output; 2=Auxiliary Relay; 3=Output #3; 4=Output #4;</i></p>
<p>Select Forced Entry Output Default: No Output</p> <p>Sets which output activates if the DOOR SENSE input opens before access is granted. This output is timed and configured by the relay "On-time".</p> <p>Press: 11 # Output # <i>Output=Output to Activate(0-4)</i> <i>1=Main Relay; 2=Auxiliary Relay; 3=Output #3; 4=Output #4;</i> <i>0=No Output</i></p>	<p>Main Relay On-time Default: 02 Seconds</p> <p>Sets the length of time the Main Relay activates when triggered. Green LED is on when Main Relay is active.</p> <p>Press: 21 # Seconds # <i>Seconds=Output time in seconds (1-60)</i></p>

<p><u>Auxiliary Relay On-time</u> <u>Default: 02 Seconds</u></p> <p>Sets the length of time the Auxiliary Relay activates when triggered.</p> <p style="text-align: center;">Press: 22 # Seconds # <i>Seconds=Output time in seconds (1-60)</i></p>	<p><u>Beep Sounds Anti-Tamper Activation</u> <u>Default: No</u></p> <p>Selects whether or not the keypad beeps during Anti-Tamper switch activation.</p> <p style="text-align: center;">Press: 45 # Sound # <i>Sound=1 for Yes, =0 for No</i></p>
<p><u>Solid-state Output #3 On-time</u> <u>Default: 02 Seconds</u></p> <p>Sets the length of time Output #3 activates when triggered.</p> <p style="text-align: center;">Press: 23 # Seconds # <i>Seconds=Output time in seconds (1-60), 99=Toggle Mode</i></p>	<p><u>Keypad Lockout Count</u> <u>Default: 3 Attempts</u></p> <p>Sets the number of incorrect entry code attempts allowed before the keypad “locks out” for 60 seconds.</p> <p style="text-align: center;">Press: 50 # Attempts # <i>Attempts=Number of attempts before lockout (2-7)</i> *Refer to Option 13 to Enable Lockout Feature</p>
<p><u>Solid-state Output #4 On-time</u> <u>Default: 02 Seconds</u></p> <p>Sets the length of time Output #4 activates when triggered.</p> <p style="text-align: center;">Press: 24 # Seconds # <i>Seconds=Output time in seconds (1-60), 99=Toggle Mode</i></p>	<p><u>Anti-Pass Back Time</u> <u>Default: No Anti-Pass Back</u></p> <p>Sets the length of time an entry code will not function after it is used.</p> <p style="text-align: center;">Press: 51 # Minutes # <i>Minutes=Time in minutes (2-4), 0=No Anti-passback</i></p>
<p><u>Door Ajar Timer</u> <u>Default: 60 Seconds</u></p> <p>Sets the amount of time the door may be held open after an authorized access. The DOOR AJAR output will activate after the time expires.</p> <p style="text-align: center;">Press: 25 # Seconds # <i>Seconds=Held open time in seconds (1-60)</i></p>	<p><u>Selects mode for Keypad LED Backlight</u> <u>Default: 30 Sec</u></p> <p>Selects whether or not the keypad back light stays OFF, lights for 30 seconds when activated or stays ON.</p> <p style="text-align: center;">Press: 52 # Output # <i>0 = Light always OFF</i> <i>1 = 30 sec light when activated (default)</i> <i>2 = Light always ON</i></p>
<p><u>Beep Sounds on Keystrokes</u> <u>Default: Yes</u></p> <p>Selects whether or not the keypad beeps as each key is pressed.</p> <p style="text-align: center;">Press: 40 # Sound # <i>Sound=1 for Yes, =0 for No</i></p>	<p><u>Changing the Beeper Sound Level</u></p> <p>The Keypad’s beeper can be set to high or low level. Remove jumper JP1 to reduce beeper sound level.</p>
<p><u>Beep Sounds During Main Relay</u> <u>Default: No</u></p> <p>Selects whether or not the keypad beeps during Main Relay activation.</p> <p style="text-align: center;">Press: 41 # Sound # <i>Sound=1 for Yes, =0 for No</i></p>	<p><u>Changing the 6-Digit Master Programming Code</u></p> <p style="text-align: center;">Press: 98 # Master Code # Master Code # <i>Master Code=The new 6-digit Master Programming Code</i></p>
<p><u>Beep Sounds During Auxiliary Relay</u> <u>Default: No</u></p> <p>Selects whether or not the keypad beeps during Auxiliary Relay activation.</p> <p style="text-align: center;">Press: 42 # Sound # <i>Sound=1 for Yes, =0 for No</i></p>	<p><u>RESETTING KEYPAD</u></p> <p><u>Master Reset</u></p> <p><i>CAUTION: Performing a master reset will clear the entire memory of the 2916P and return all programmable options to the factory default values. ALL ENTRY CODES WILL BE ERASED. NOTE: The Master Code will NOT be reset.</i></p> <p>STEP 1 Disconnect power from the keypad. STEP 2 Press and hold down the * and # keys. STEP 3 Apply power to the keypad, continue holding the keys down until the red indicator starts flashing STEP 4 Release the keys. The red and yellow indicators will remain lit until the process is complete, then the yellow indicator will go out.</p>
<p><u>Beep Sounds During Output #3</u> <u>Default: No</u></p> <p>Selects whether or not the keypad beeps during Output #3 activation.</p> <p style="text-align: center;">Press: 43 # Sound # <i>Sound=1 for Yes, =0 for No</i></p>	<p><u>Resetting the Master Code</u></p> <p>STEP 1 Remove the 2916P from the wall and disconnect power from the keypad. STEP 2 Locate & Remove jumper at JP2. Reference page 2. STEP 3 Re-apply power. You will get a single beep and the yellow LED will flash momentarily. STEP 4 Replace jumper on JP2. THE MASTER PROGRAMMING CODE IS NOW 123456.</p>
<p><u>Beep Sounds During Output #4</u> <u>Default: No</u></p> <p>Selects whether or not the keypad beeps during Output #4 activation.</p> <p style="text-align: center;">Press: 44 # Sound # <i>Sound=1 for Yes, =0 for No</i></p>	

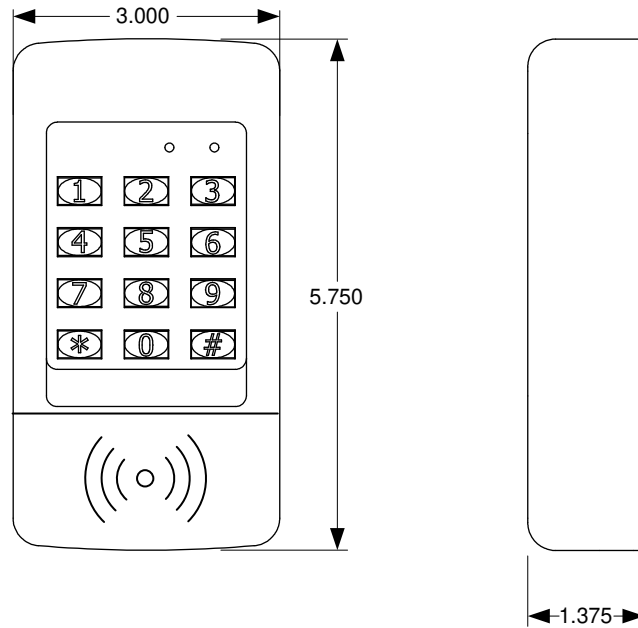

SURFACE MOUNT

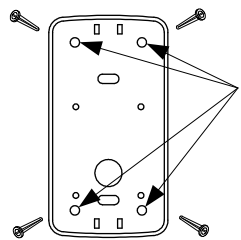

4X Mount at holes
With supplied
screws and hole
expansion anchors

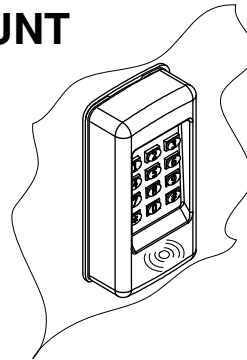

MOUNTING TO SINGLE GANG RECESSED OUTLET BOX

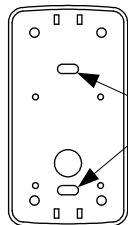

2X
Mount
at slots

