

**MORTISE CYLINDER KEY SWITCH  
INSTALLATION & Wiring INSTRUCTIONS**

29KS Key Switch Assemblies are compatible with U.S. standard, 1.125" and 1.25" mortise key cylinders and interchangeable core cylinders (not included). Compatibility with a new or existing facility mechanical key system is maintained. Standard switch assemblies are Single Gang box mounted. Assemblies equipped with narrow faceplates are mounted directly to the door frame.

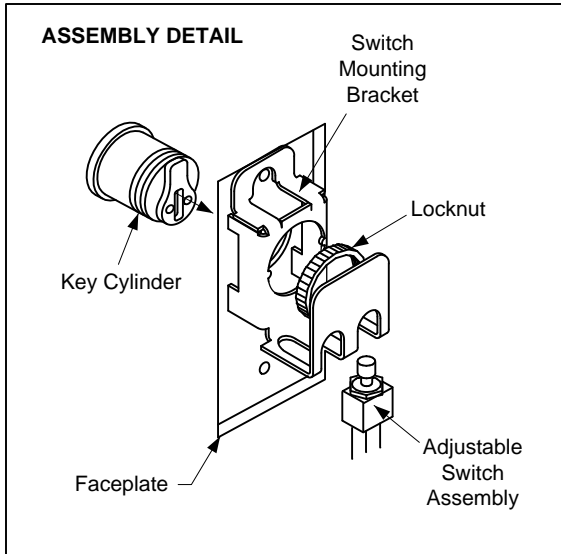

**KEY SWITCH ASSEMBLY PROCEDURE**

1. If you are using a Hager supplied cylinder, a 3978 cam must also be ordered and installed on the mortise cylinder. If you are using another manufacturer's key cylinder, use the manufacturer's equivalent.
2. Insert the key cylinder through the front of the faceplate. Make sure the key cylinder is oriented correctly and the tailpiece is in the upright position.
3. While holding the key cylinder in place, slide the switch mounting bracket onto the back of the cylinder. Align the triangular tabs on the mounting bracket with the corresponding notches on the barrel of the key cylinder.  
*On the 29KS Series, the bracket mounting holes will align with the faceplate mounting holes.*
4. Secure the key cylinder by screwing the supplied Locknut to the back of the cylinder. Tighten firmly. Insert key into the cylinder and verify the activation of the switch by turning the key. If necessary, adjust the switch position to ensure that the cam makes contact with the center of the switch plunger. The switch height should be adjusted so that the cam does not apply excessive downward pressure to the switch.
5. Once the electrical connections are completed, mount the key switch assembly:  
*For the 29KS Series, attach to a single gang mortise or surface mounted box.*

**STANDARD FEATURES**

- Compatible with 1-1/8" and 1-1/4" standard and interchangeable core mortise key cylinders (**supplied by others**).
- Key cylinder recessed for tamper resistance.
- Tamper resistant spanner screws.
- **Contact Rating:** 6 amps @ 30VDC.
- **Wire Leads:** 7", 22 gauge.
- Large actuator assembly for positive & consistent circuit activation.

**OPTIONAL KEY CYLINDER**

- 3902** – 1.125" Mortise Key Cylinder (purchase separately)
- 3978** – Cam (purchase separately)

**FACEPLATE DIMENSIONS**

**29KS:** 4.5"H x 2.875"W x 20 Ga.

**ASSEMBLY TOOLS:**

For convenience, a small spanner tool is provided with the assembly for fastening of spanner security screws

**Use Hager 3978 Cam  
with all 29KS switches**

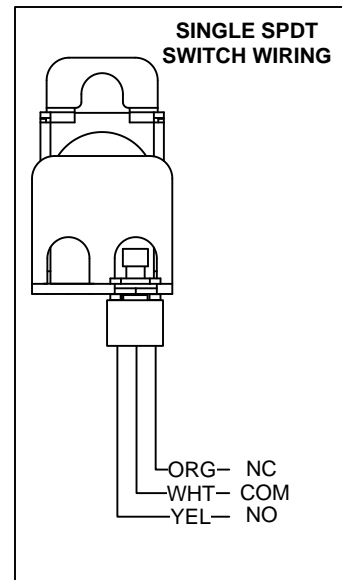

- ASD AA (ALTERNATE ACTION) SPDT
- MSD MO (MOMENTARY) SPDT
- ADD AA (ALTERNATE ACTION) DPDT\*
- MDD MO (MOMENTARY) DPDT\*

\*NOTE: DPDT switches will have 2 sets of YEL, WHT, and ORG wires.

**Single Color LED Wiring (L1G, L1R, or L2  
Option)**

