

NOTES:

1. INSTALL LOCK, INSERT THUMBTURN, POSITION THE ROSE AND MARK MOUNTING HOLES. REMOVE THUMBTURN AND PREPARE HOLES AS SHOWN.
2. ALIGN CENTERLINE OF STRIKE WITH THE CENTERLINE OF THE LOCK
3. RIGHT HAND PREP SHOWN

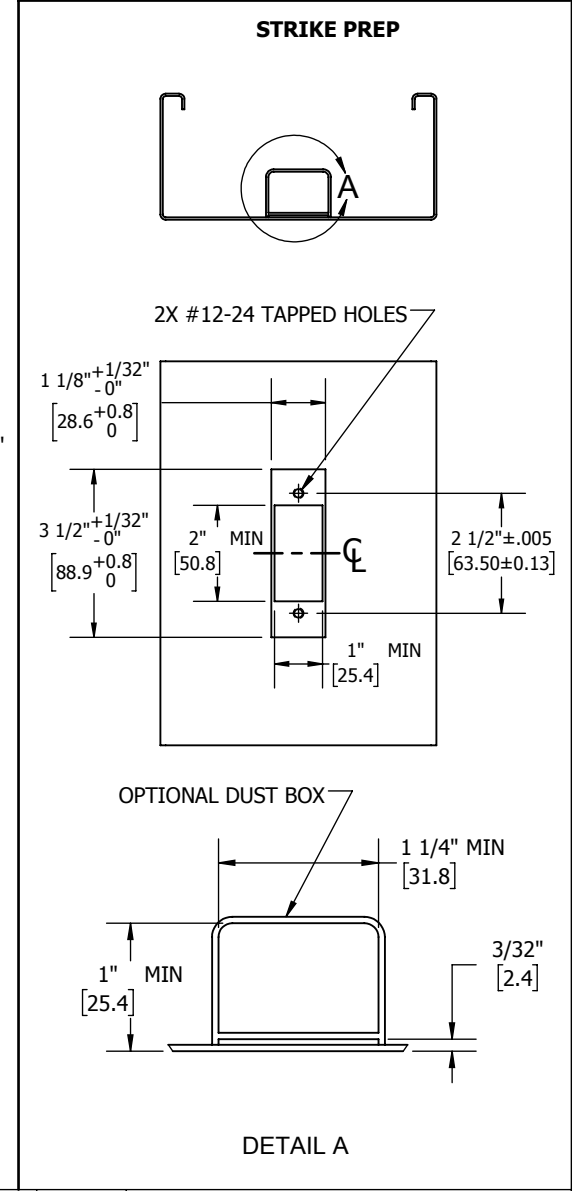
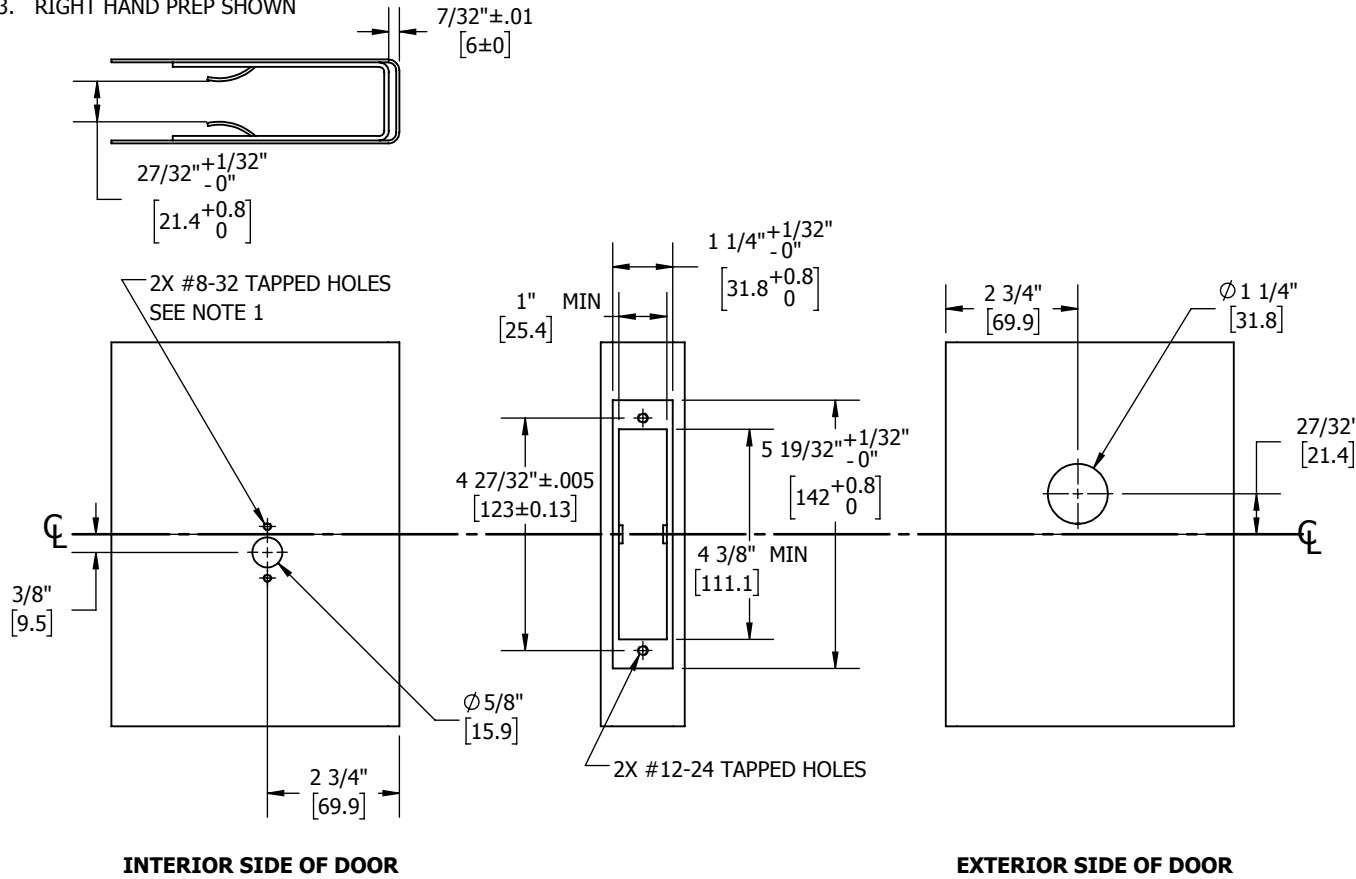

HAGER RESERVES THE RIGHT TO MAKE DESIGN CHANGES WITHOUT NOTICE. CALL HAGER ENGINEERING AT 1-800-325-9995 FOR THE LATEST REVISION DATE OF TEMPLATE.

PRIMARY DIMENSIONS SHOWN IN INCHES, DIMENSIONS IN [] ARE MILLIMETERS.

DRAWN	KJW	2/20/2019
ENG. APPR.	MAM	2/22/2019
MATERIAL	Material <not specified>	
FINISH	-	
DO NOT SCALE DRAWING		

3835	
STEEL DOOR PREP TEMPLATE FOR SLIDING DOOR MORTISE LOCK, CYLINDER X THUMBTURN	
SIZE	REV.
A	-
DWG. NO.	T-LS02385
SCALE: 1:4	WEIGHT: 0.45
SHEET 1 OF 5	

NOTES:

1. ALIGN CENTERLINE OF STRIKE WITH THE CENTERLINE OF THE LOCK
2. RIGHT HAND PREP SHOWN

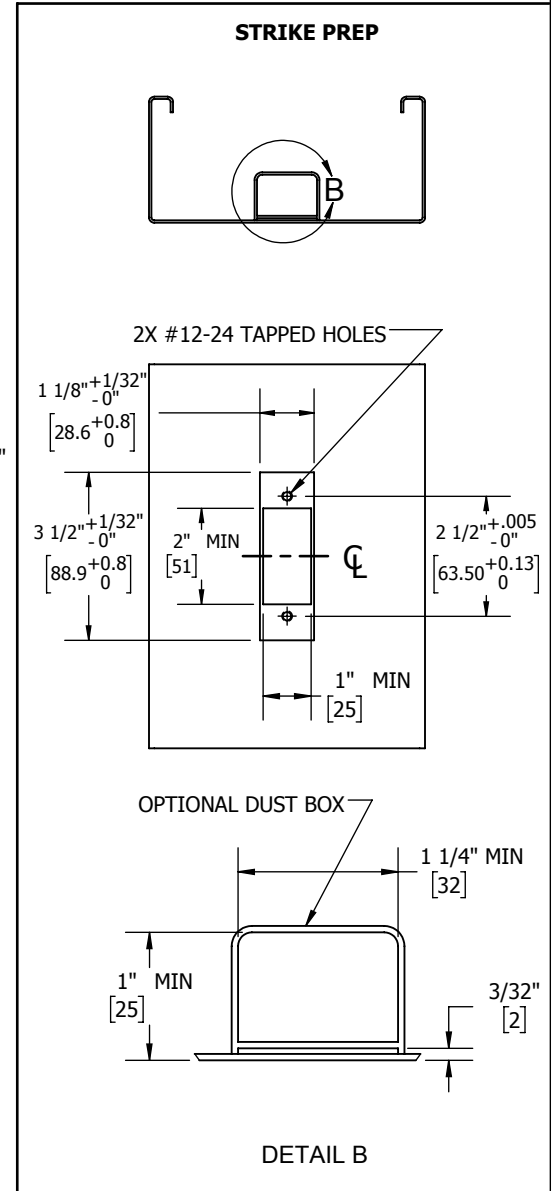
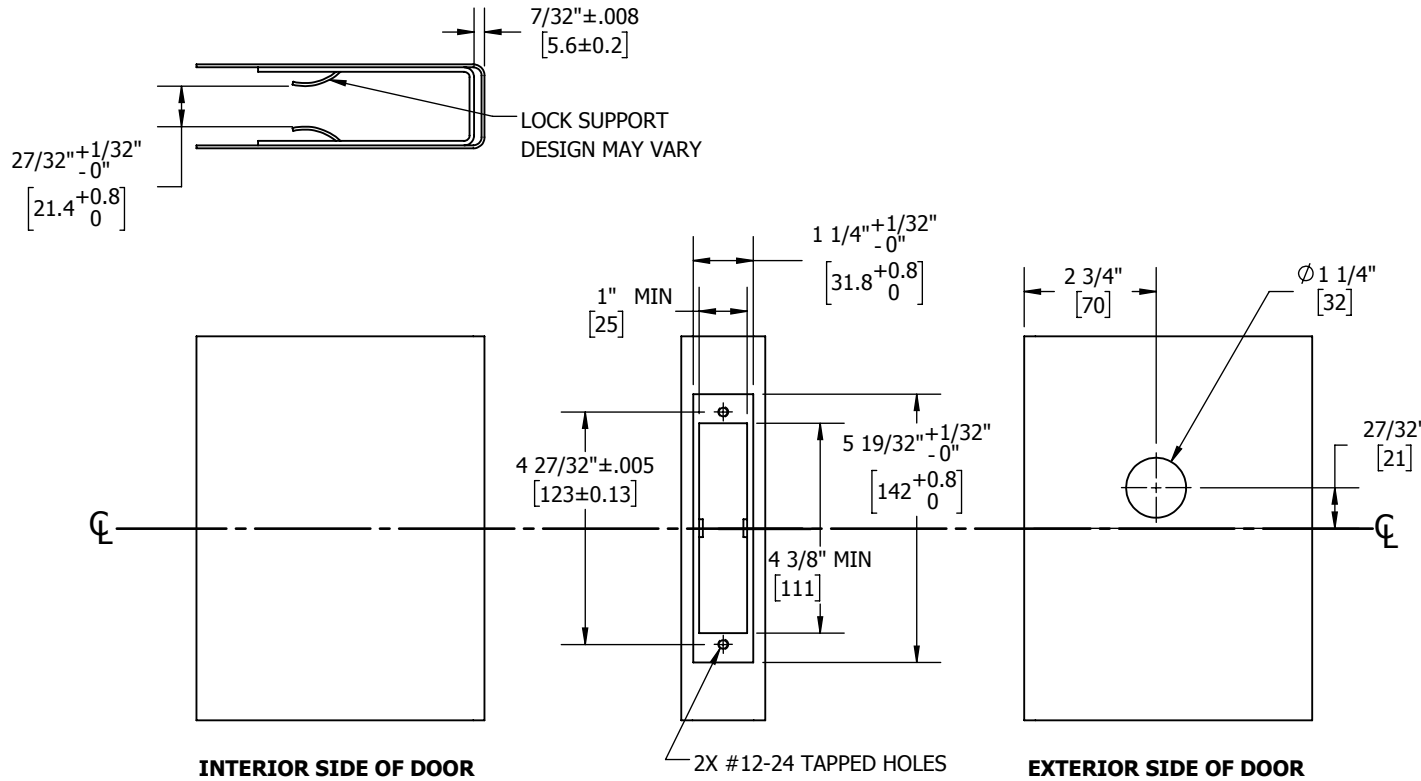

HAGER RESERVES THE RIGHT TO MAKE DESIGN CHANGES WITHOUT NOTICE. CALL HAGER ENGINEERING AT 1-800-325-9995 FOR THE LATEST REVISION DATE OF TEMPLATE.

PRIMARY DIMENSIONS SHOWN IN INCHES, DIMENSIONS IN [] ARE MILLIMETERS.

MATERIAL Material <not specified>

FINISH -

DO NOT SCALE DRAWING

DRAWN KJW 2/20/2019

ENG. APPR. MAM 2/22/2019

Q.A.

3836
STEEL DOOR PREP TEMPLATE FOR SLIDING DOOR MORTISE LOCK, SINGLE CYLINDER

SIZE DWG. NO. REV.

A T-LS02385 -

SCALE: 1:4 WEIGHT: 3.52 SHEET 2 OF 5

NOTES:

1. INSTALL LOCK, INSERT THUMBTURN, POSITION THE ROSE AND MARK MOUNTING HOLES. REMOVE THUMBTURN AND PREPARE HOLES AS SHOWN.
2. ALIGN CENTERLINE OF STRIKE WITH THE CENTERLINE OF THE LOCK
3. RIGHT HAND PREP SHOWN

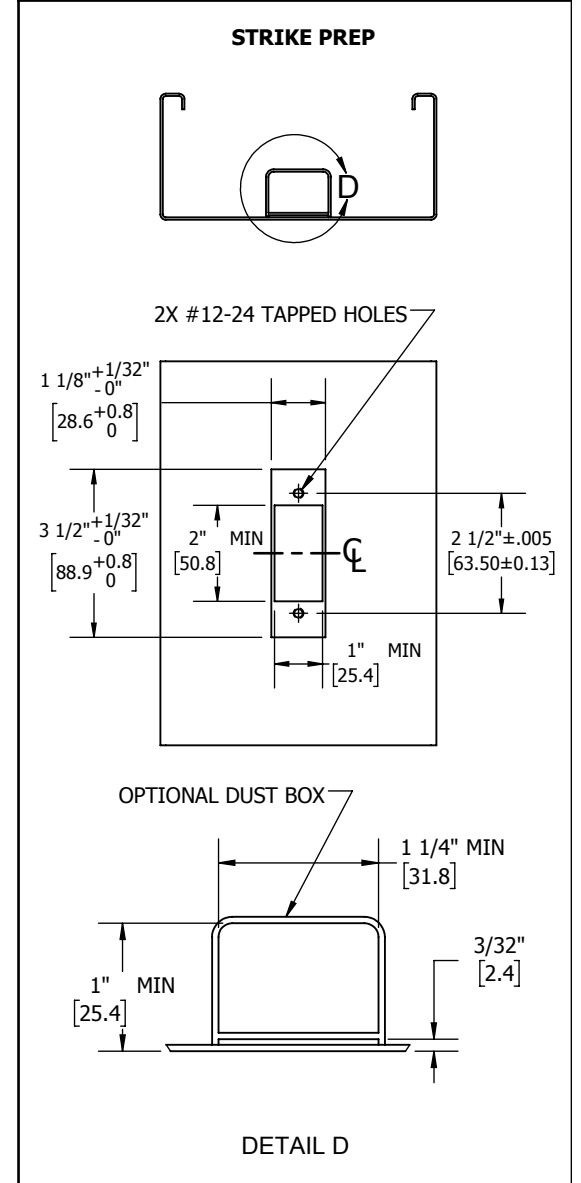
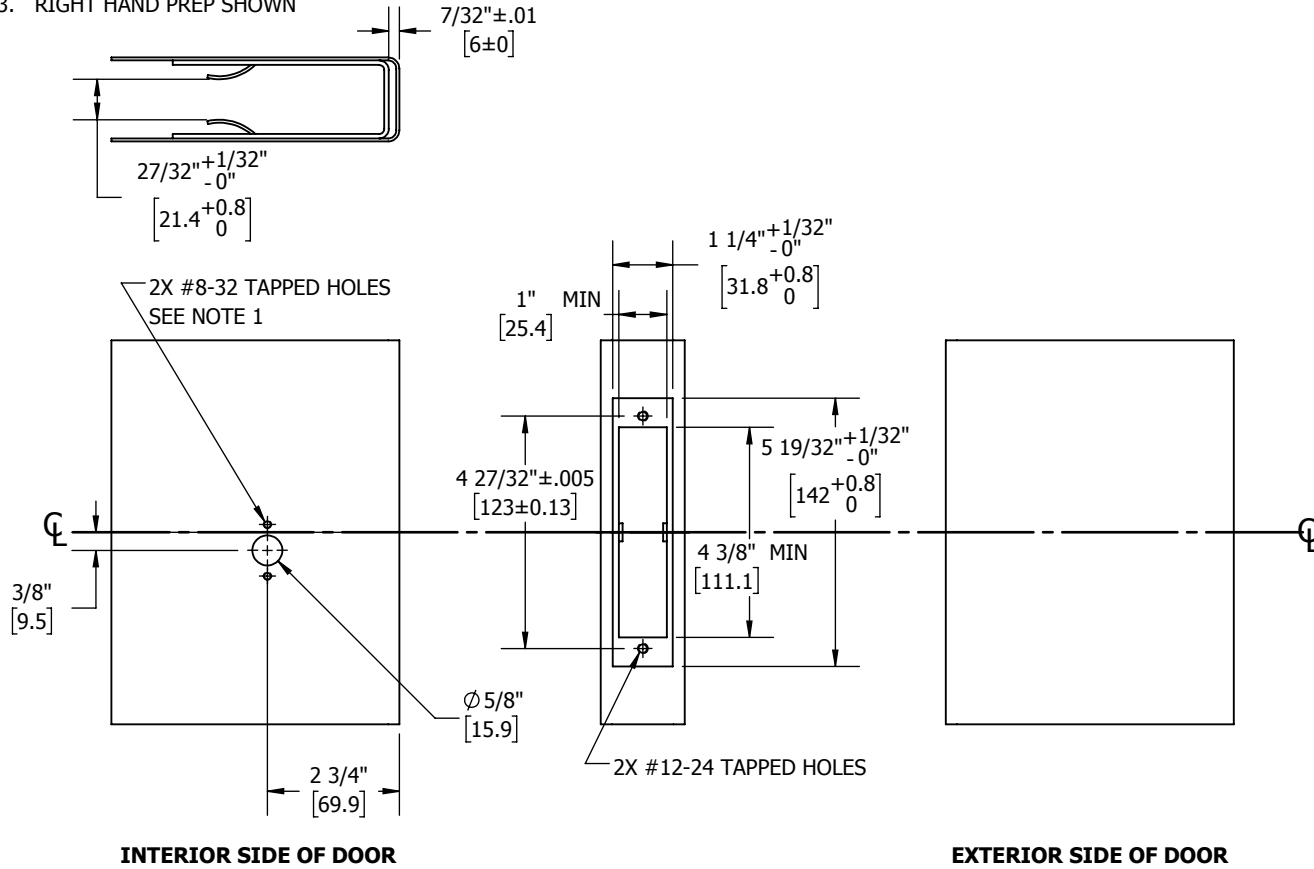

HAGER RESERVES THE RIGHT TO MAKE DESIGN CHANGES WITHOUT NOTICE. CALL HAGER ENGINEERING AT 1-800-325-9995 FOR THE LATEST REVISION DATE OF TEMPLATE.

PRIMARY DIMENSIONS SHOWN IN INCHES, DIMENSIONS IN [] ARE MILLIMETERS.

DRAWN	KJW	2/20/2019
ENG. APPR.	MAM	2/22/2019
MATERIAL	Material <not specified>	
FINISH	-	
DO NOT SCALE DRAWING		

3838	
STEEL DOOR PREP TEMPLATE FOR SLIDING DOOR MORTISE LOCK, THUMBTURN ONLY	
SIZE	REV.
A	-
DWG. NO.	T-LS02385
SCALE: 1:4	WEIGHT: 0.46
SHEET 4 OF 5	

NOTES:

1. INSTALL LOCK, INSERT THUMBTURN, POSITION THE ROSE AND MARK MOUNTING HOLES. REMOVE THUMBTURN AND PREPARE HOLES AS SHOWN.
2. ALIGN CENTERLINE OF STRIKE WITH THE CENTERLINE OF THE LOCK
3. RIGHT HAND PREP SHOWN

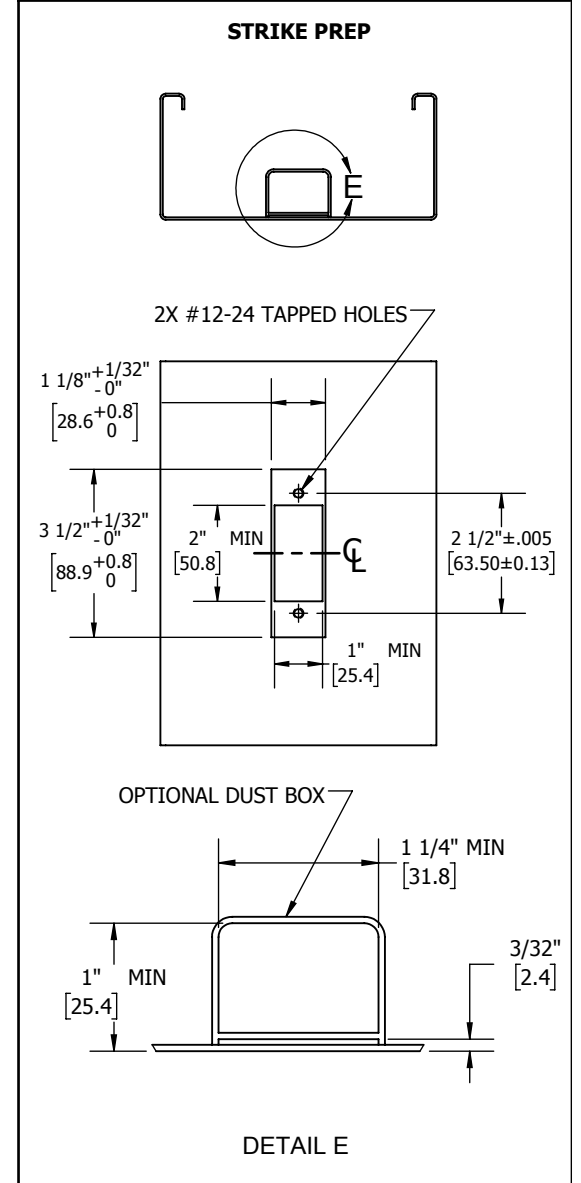
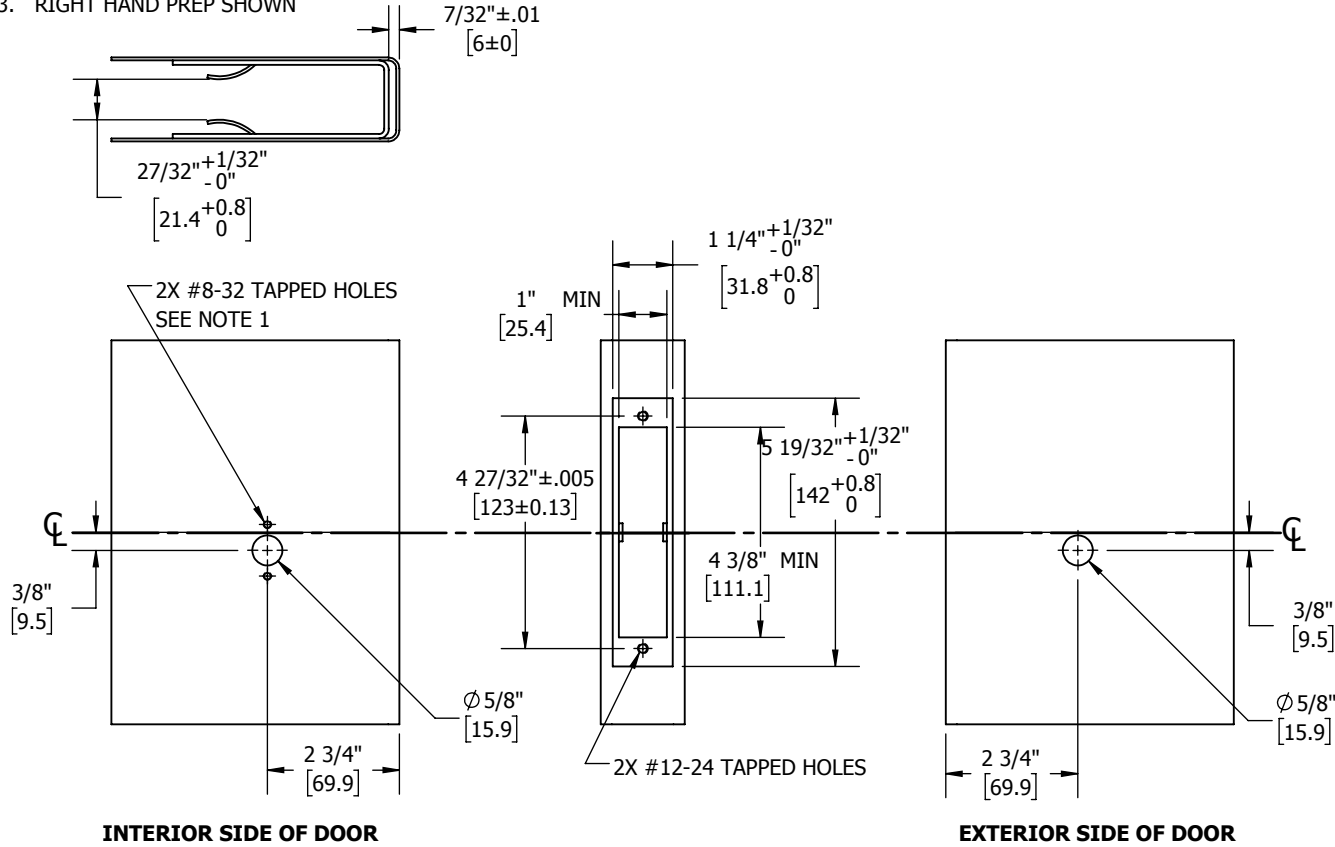

HAGER RESERVES THE RIGHT TO MAKE DESIGN CHANGES WITHOUT NOTICE. CALL HAGER ENGINEERING AT 1-800-325-9995 FOR THE LATEST REVISION DATE OF TEMPLATE.

PRIMARY DIMENSIONS SHOWN IN INCHES, DIMENSIONS IN [] ARE MILLIMETERS.

DRAWN	KJW	2/20/2019
ENG. APPR.	MAM	2/22/2019
MATERIAL Material <not specified>		
FINISH -		
DO NOT SCALE DRAWING		

3839		REV.
STEEL DOOR PREP TEMPLATE: SLIDING DOOR MORTISE LOCK, THUMBTURN W/ EMERGENCY KEY		-
SIZE A	DWG. NO. T-LS02385	REV. -
SCALE: 1:4	WEIGHT: 0.45	SHEET 5 OF 5