

4600 TRIM TEMPLATE

- STANDARD INSTALLATION
- FOR NL TRIM MODELS
- LHR AND RHR HANDING

PRINT 8-1/2" X 11" FULL SIZE

NOTE A

TRIM MOUNTING CLEARANCE HOLES:
 DRILL ϕ 1/2" [13] HOLES ON PULL SIDE.
 DRILL ϕ 5/16" [8] HOLES ON PUSH SIDE.
 (2 PLACES)

TRIM TAILPIECE CLEARANCE HOLE:
 DRILL ϕ 1/2" [13] THRU HOLE.

TRIM ϕ CORRESPONDS TO
 EXIT DEVICE ϕ
 (NOTE A)

LEFT HAND REVERSE (LHR) SHOWN

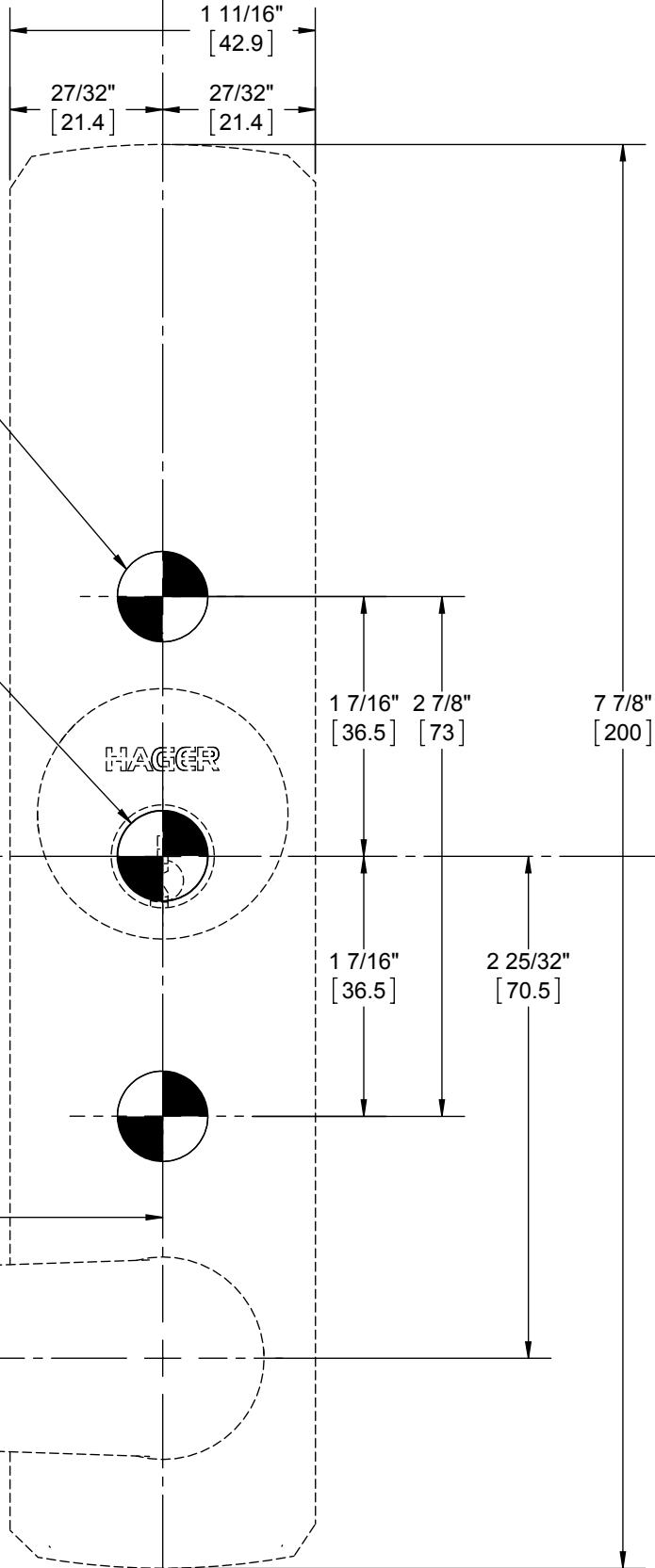

NOTE A

NOTES:

- SEE TRIM INSTALLATION INSTRUCTIONS FOR ALIGNMENT DETAILS. (ϕ = CENTERLINE)
- HOLE LOCATIONS IDENTIFIED BY THE
- PRIMARY DIMENSIONS SHOWN IN INCHES, DIMENSIONS IN [] ARE MILLIMETERS.



TEMPLATE NO: 27390053
 REV: 01

DRAWING NO: T-ED01195
 SHEET 1 OF 1

HAGER COMPANIES 139 Victor Street, St. Louis, MO 63104
 (800) 325-9995 - Fax (800) 782-0149