

# FULL MORTISE TEMPLATE HINGES

Template No. T - DROP LEAF  
Rev. '96

SIZES: 4 1/2 x 4, 4 1/2 x 4 1/2, 4 1/2 x 5, 4 1/2 x 6,  
4 1/2 x 7, 4 1/2 x 8

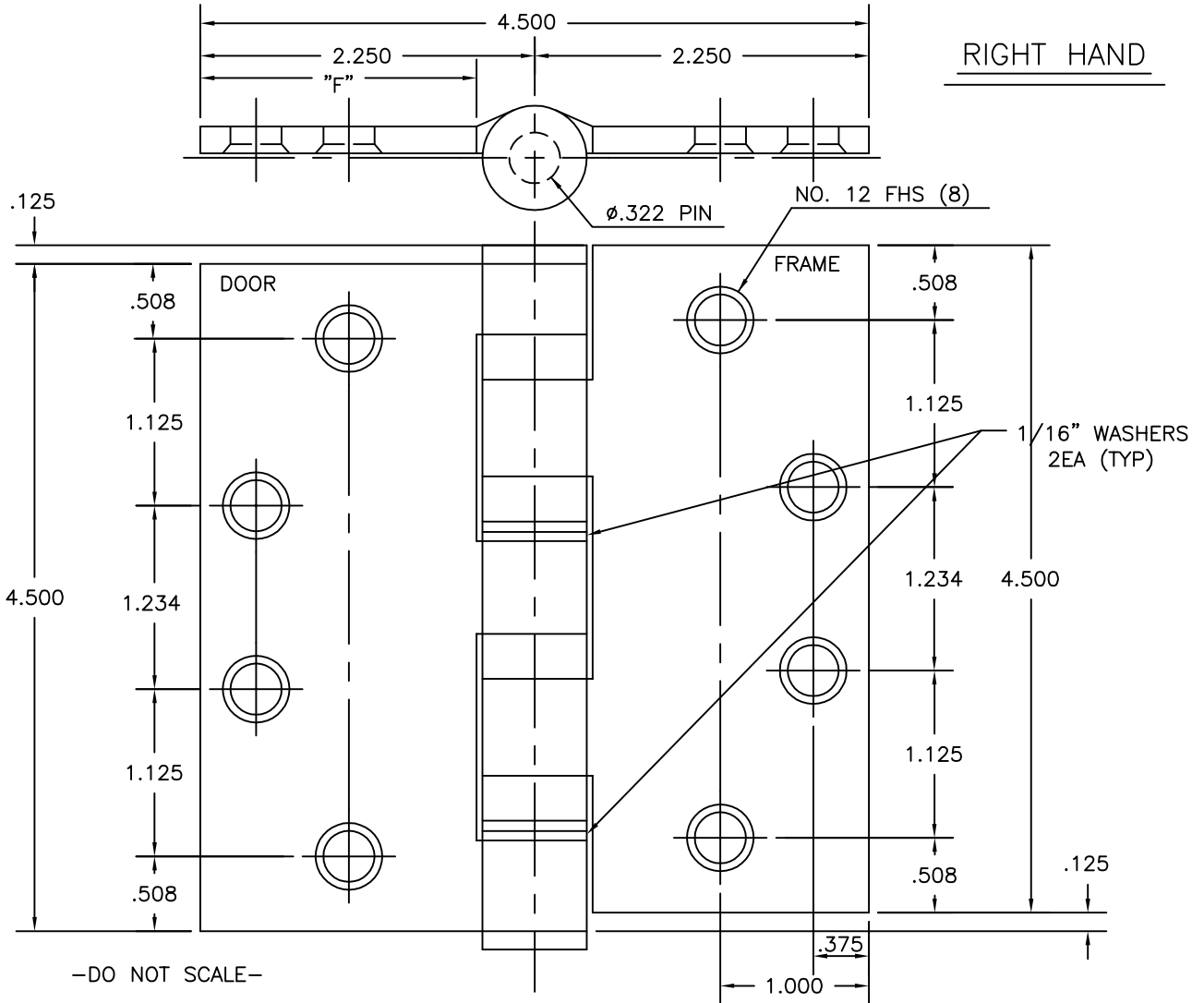

-DO NOT SCALE-

CATALOG NUMBER		METAL GAUGE	(E) KNUCKLE DIAMETER	(F) DISTANCE FROM EDGE OF LEAF TO SWAGE LINE					
STEEL HINGES	NON-FERROUS HINGES			4 1/2 x 4	4 1/2 x 4 1/2	4 1/2 x 5	4 1/2 x 6	4 1/2 x 7	4 1/2 x 8
700	800	.134	39/64	1 5/8	1 7/8	---	---	---	---
1279	1191	.134	39/64	1 5/8	1 7/8	2 1/8	2 5/8	3 1/8	3 5/8
AB700	AB800	.134	39/64	1 5/8	1 7/8	---	---	---	---
BB1174	BB1193	.134	39/64	1 3/8	1 5/8	---	---	---	---
BB1279	BB1191	.134	39/64	1 5/8	1 7/8	2 1/8	2 5/8	3 1/8	3 5/8
AB750	AB850	.180	45/64	1 9/16	1 13/16	2 1/16	2 9/16	3 1/16	3 9/16
BB1168	BB1199	.180	45/64	1 9/16	1 13/16	2 1/16	2 9/16	3 1/16	3 9/16

ALL DIMENSIONS ARE IN INCHES.



Wood Screw Size- No. 12 x 1 1/4" F.H. Machine Screw Size- 12-24 x 1/2" F.H.  
Hospital type and round corner template hinges conform to the above screw size and location. They are designated by "HT" and "RC" to catalog number.

Hager template hinges are made in size, gauge and with screw holes located to conform to ANSI-A156.7.

HAGER RESERVES THE RIGHT TO MAKE DESIGN CHANGES WITHOUT NOTICE. CALL HAGER ENGINEERING AT 1-800-325-9995 FOR LATEST REVISION DATE OF TEMPLATE.

HAGER COMPANIES  
139 VICTOR STREET  
P.O. BOX 12300  
ST. LOUIS, MISSOURI 63157-0300

Template No. T - DROP LEAF