

REVISIONS			
REV.	DESCRIPTION	DATE	APPROVED
01	ADDED TABLE	7/24/2007	

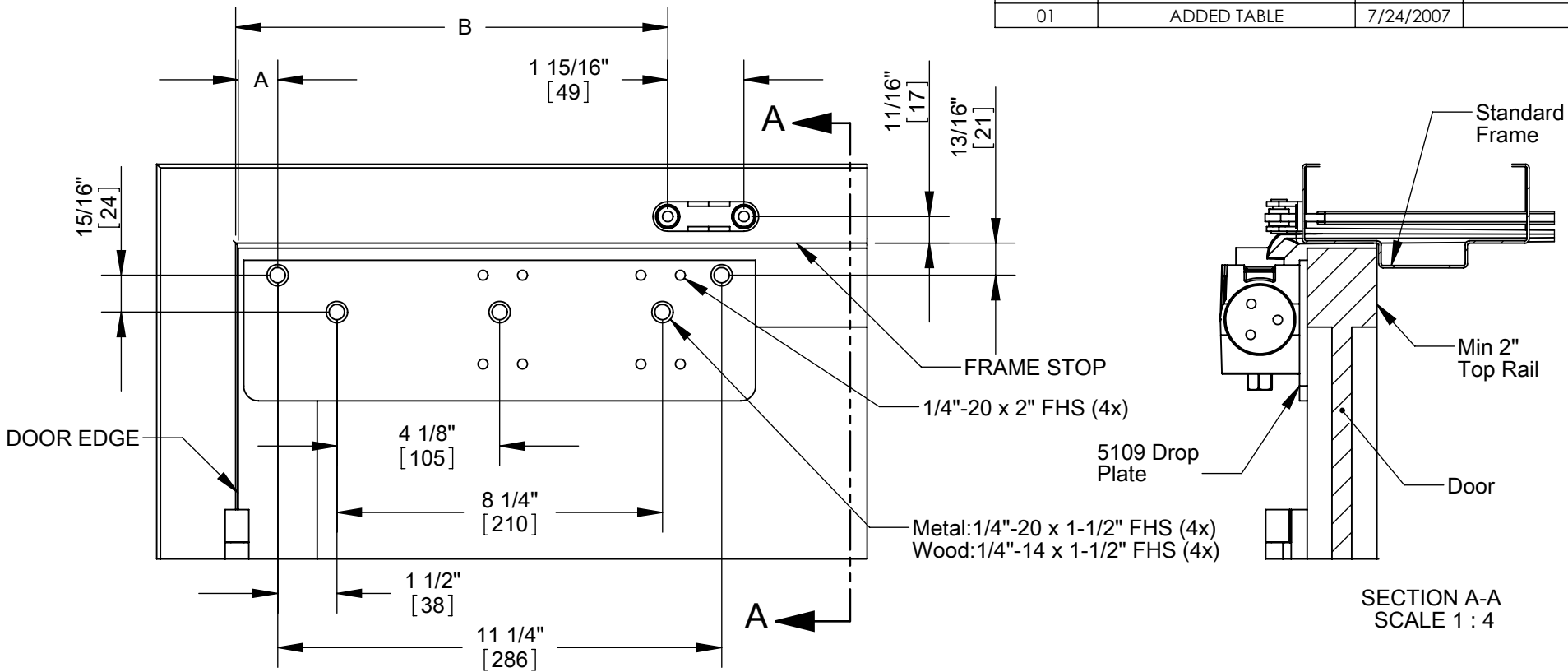

SECTION A-A
SCALE 1 : 4

Degree of Opening	Dim A	Dim B
Up to 100°	3" (76.2mm)	12-13/16" (325.4mm)
Up to 130°	1" (25.4mm)	10-13/16" (274.6mm)

• RIGHT HAND DOOR SHOWN, LEFT HAND OPPOSITE.



HAGER RESERVES THE RIGHT TO MAKE DESIGN CHANGES WITHOUT NOTICE. CALL HAGER ENGINEERING AT 1-800-325-9995 FOR THE LATEST REVISION DATE OF TEMPLATE.

PRIMARY DIMENSIONS SHOWN IN INCHES, DIMENSIONS IN [] ARE MILLIMETERS.

DRAWN	T Sveitlis	2/21/06
ENG. APPR.		
MATERIAL	-	
FINISH	per order	
DO NOT SCALE DRAWING		
TOLERANCES: FRACTIONAL: ±0.015" ANGULAR: MACH: ± 1° BEND: ±1° TWO PLACE DECIMAL: ±0.01" THREE PLACE DECIMAL: ±0.004"		

5109 Regular Arm Mounting Plate Template		
SIZE	DWG. NO.	REV.
A	T-CL00002	-01
SCALE: 1:4	WEIGHT: -	SHEET 1 OF 1