

FULL MORTISE ETW ELECTRIC HINGE TEMPLATE

SIZE: 4 1/2"
FOR SQUARE EDGE DOORS

ETW MAXIMUM
ELECTRICAL RATING
CONTACT THROUGH WIRE
VOLTS 48V DC
AMPERES 3.5A
CONTINUOUS CURRENT
16.0A CURRENT INRUSH
(300 MILLISECONDS)



CATALOG NUMBER	METAL GAUGE
STEEL HINGES	
AB7501	.180

ALL DIMENSIONS ARE IN INCHES.

DOOR AND FRAME PREPARATION

DOOR PREPARATION

DRILL AND DEBURR ϕ 3/4" HOLE IN DOOR
REINFORCEMENT FOR THROUGH WIRES

FRAME PREPARATION

- RIGHT HAND INSTALLATION—
DRILL AND DEBURR ϕ 3/4" HOLE FOR
THROUGH WIRES IN FRAME REINFORCEMENT
PLATE ON UPPER RIGHT.
- LEFT HAND INSTALLATION—
DRILL AND DEBURR ϕ 3/4" HOLE FOR
THROUGH WIRES IN FRAME REINFORCEMENT
PLATE ON BOTTOM LEFT.

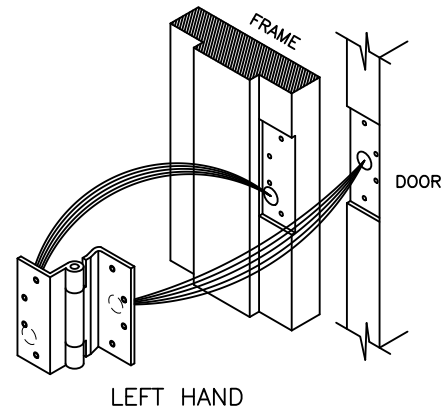
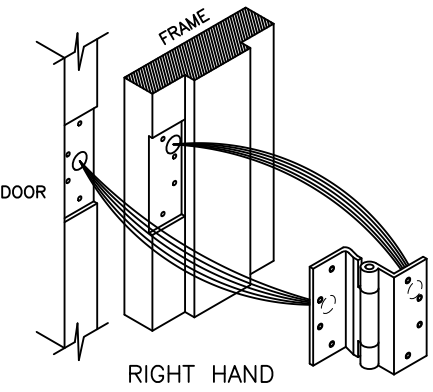
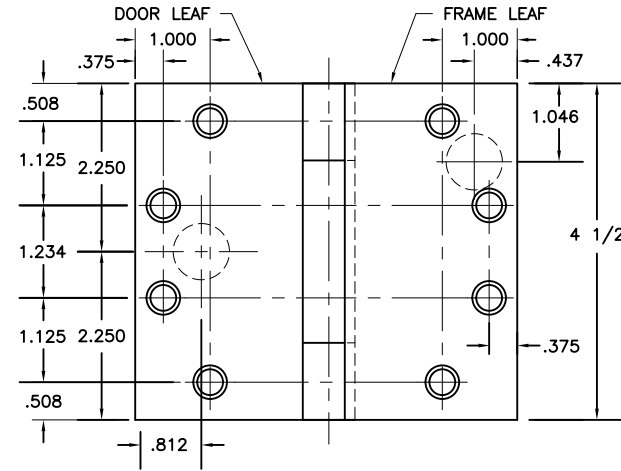
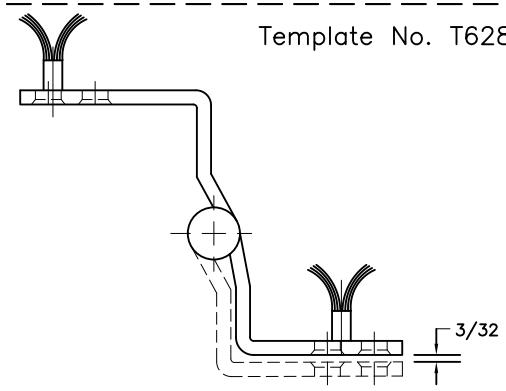

INSTALLATION

FAILURE TO FOLLOW THESE INSTRUCTIONS WILL VOID WARRANTY.

- Attach wires from hinge to the appropriate wires as described in the wiring diagram supplied for your project by others.
- Insulate bare ends of any unused wires.
- Check the fit of the hinge in the door and frame preparation. Hinge must fit easily in the mortise and not bind when fully installed. Forcing the hinge into a faulty preparation by hammering or bending can cause serious damage and/or shortened life.
- Carefully slide wires back through the access holes in the door and frame. Make sure that the wires are placed so they will not be cut or pinched as installation is completed.
- Do not remove pin or attempt to disassemble hinge. Electric hinges should always be installed in the center hinge location.
- For grout filled frame use Hager mortar box.
- Designed to swing doors completely clear of the opening when door is opened 95°. When opened 90°, door projects 11/64 (4.37mm) past stop of jamb.
- This hinge alters the normal pivot point of door. For door closers, friction or overhead door holders to be used in conjunction with this hinge, consult manufacturer of the device for application details.
- Hospital type template hinges conform to the above screw size and location, and they are designated by adding "HT" to catalog number.
- Hager template hinges are made within gauge and with screw holes located to conform to ANSI-A156.7.
- Machine Screw Size— #12-24 x 1/2" F.H.
- Wood Screw Size— #12 x 1 1/4" F.H.

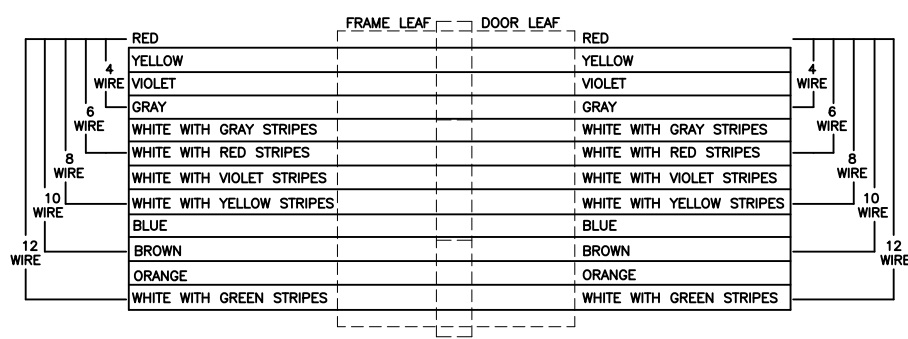

—DO NOT SCALE—

No.	REVISION	BY	DATE
3	ECO CT05035	RAM	8-16-05

HAGER RESERVES THE RIGHT TO MAKE DESIGN CHANGES WITHOUT NOTICE. CALL HAGER ENGINEERING AT 1-800-325-9995 FOR LATEST REVISION DATE OF TEMPLATE.