

FULL MORTISE  
TEMPLATE HINGES  
ROUND CORNERS

Template No. T304RC  
Rev. '96

SIZES: 3 1/2 x 3 1/2 --- 3 1/2 x 5 --- 3 1/2 x 6  
(88.90 x 88.90) (88.90 x 127.00) (88.90 x 152.40)

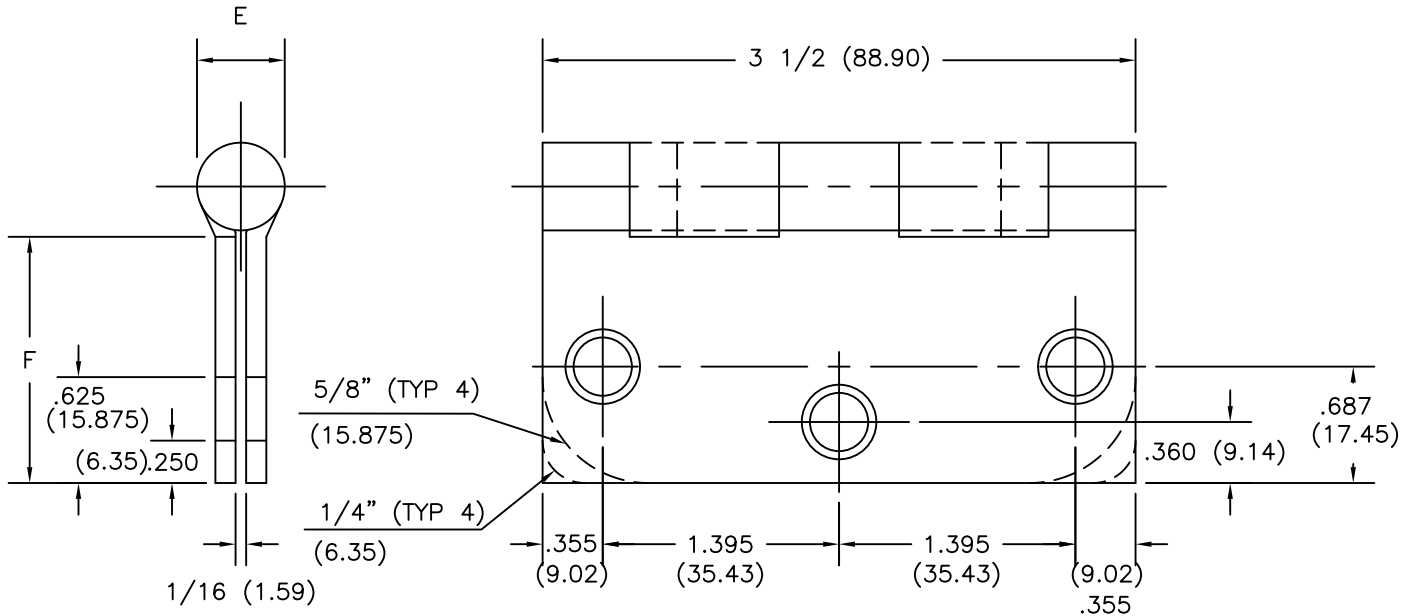

-DO NOT SCALE-

CATALOG NUMBER		METAL GAUGE	(E) KNUCKLE DIAMETER	(F) DISTANCE FROM EDGE OF LEAF TO SWAGE LINE		
STEEL HINGES	NON-FERROUS HINGES			3 1/2 x 3 1/2 (88.90 x 88.90)	3 1/2 x 5 (88.90 x 127.00)	3 1/2 x 6 (88.90 x 152.40)
700	800	.119 (3.02)	19/32 (15.08)	1 5/16 (33.34)	---	---
1279	1191	.119 (3.02)	17/32 (13.49)	1 3/8 (34.93)	2 1/8 (53.98)	2 5/8 (66.68)
AB700	AB800	.119 (3.02)	19/32 (15.08)	1 5/16 (33.34)	---	---
BB1279	BB1191	.119 (3.02)	17/32 (13.49)	1 3/8 (34.93)	2 1/8 (53.98)	2 5/8 (66.68)

ALL NON-BRACKETED DIMENSIONS ARE IN INCHES, ALL BRACKETED DIMENSIONS ARE IN MILLIMETERS.

Machine Screw Size- 10-24 x 1/2" F.H. WITH NO. 9 HEAD

Wood Screw Size- No. 9 x 1" F.H.



Hospital type and round corner template hinges conform to the above screw size and location. They are designated by "HT" and "RC" to catalog number.

Hager template hinges are made in size and with screw holes located to conform to ANSI-A156.7.

HAGER RESERVES THE RIGHT TO MAKE DESIGN CHANGES WITHOUT NOTICE. CALL HAGER ENGINEERING AT 1-800-325-9995 FOR LATEST REVISION DATE OF TEMPLATE.

HAGER COMPANIES  
139 VICTOR STREET  
P.O. BOX 12300  
ST. LOUIS, MISSOURI 63157-0300

Template No. T304RC