

REVISIONS			
REV.	DESCRIPTION	DATE	APPROVED
1	ECO CL07002	4/11/2007	

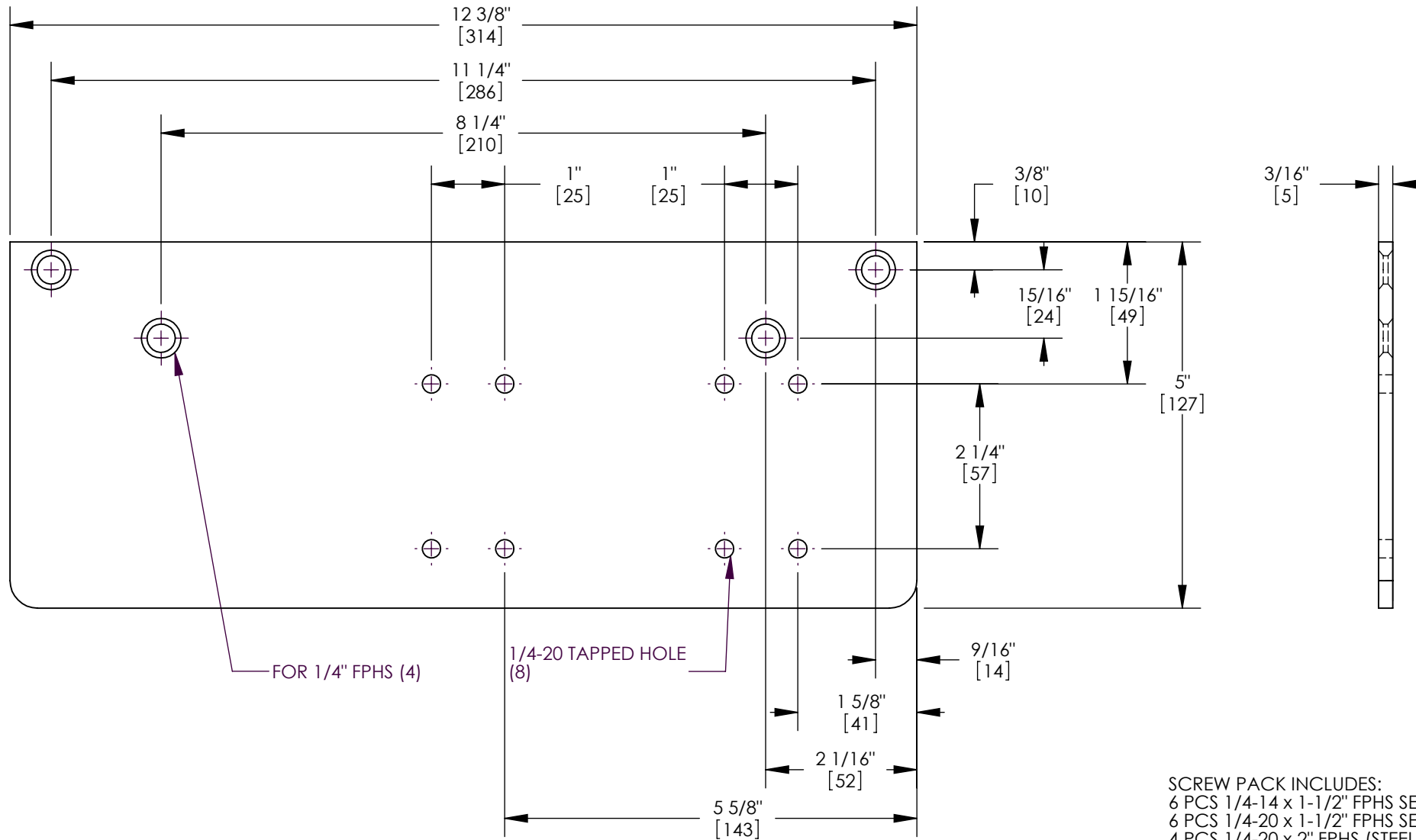

SCREW PACK INCLUDES:  
 6 PCS 1/4-14 x 1-1/2" FPHS SELF DRILLING (STEEL)  
 6 PCS 1/4-20 x 1-1/2" FPHS SELF DRILLING (STEEL)  
 4 PCS 1/4-20 x 2" FPHS (STEEL)



HAGER RESERVES THE RIGHT TO MAKE DESIGN CHANGES WITHOUT NOTICE. CALL HAGER ENGINEERING AT 1-800-325-9995 FOR THE LATEST REVISION DATE OF TEMPLATE.

PRIMARY DIMENSIONS SHOWN IN INCHES, DIMENSIONS IN [ ] ARE MILLIMETERS.

DRAWN	DMH	07-19-06
ENG. APPR.	-	-
MATERIAL	-	-
FINISH	PER ORDER	
TOLERANCES:		
FRACTIONAL: ±0.015"		
ANGULAR: MACH: ±1° BEND: ±1°		
TWO PLACE DECIMAL: ±0.01"		
THREE PLACE DECIMAL: ±0.004"		
DO NOT SCALE DRAWING		

5110 DROP PLATE PARALLEL ARM		REV.
SIZE	DWG. NO.	
B	S-CL00076	-01
SCALE: 1:2	WEIGHT: 3.34	SHEET 1 OF 1