

REVISIONS			
REV.	DESCRIPTION	DATE	APPROVED
01	UPDATED DIMENSIONS & ADDED SCREW PACK INFO	9/15/2006	

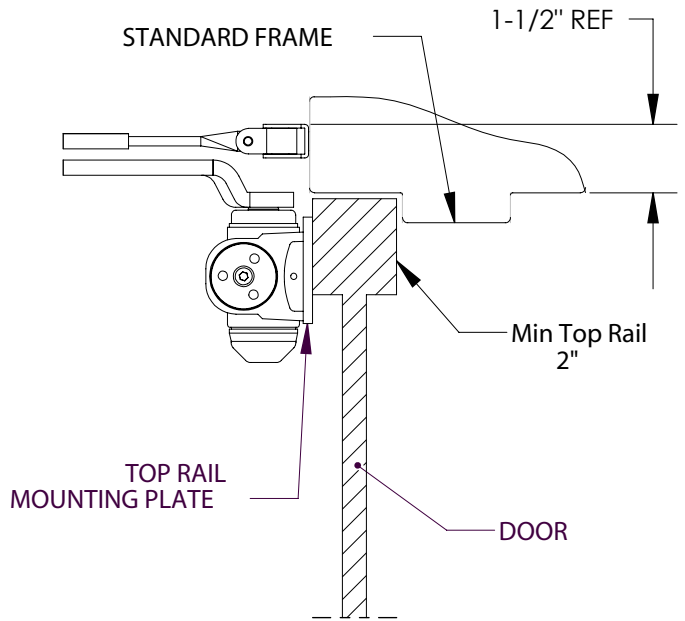
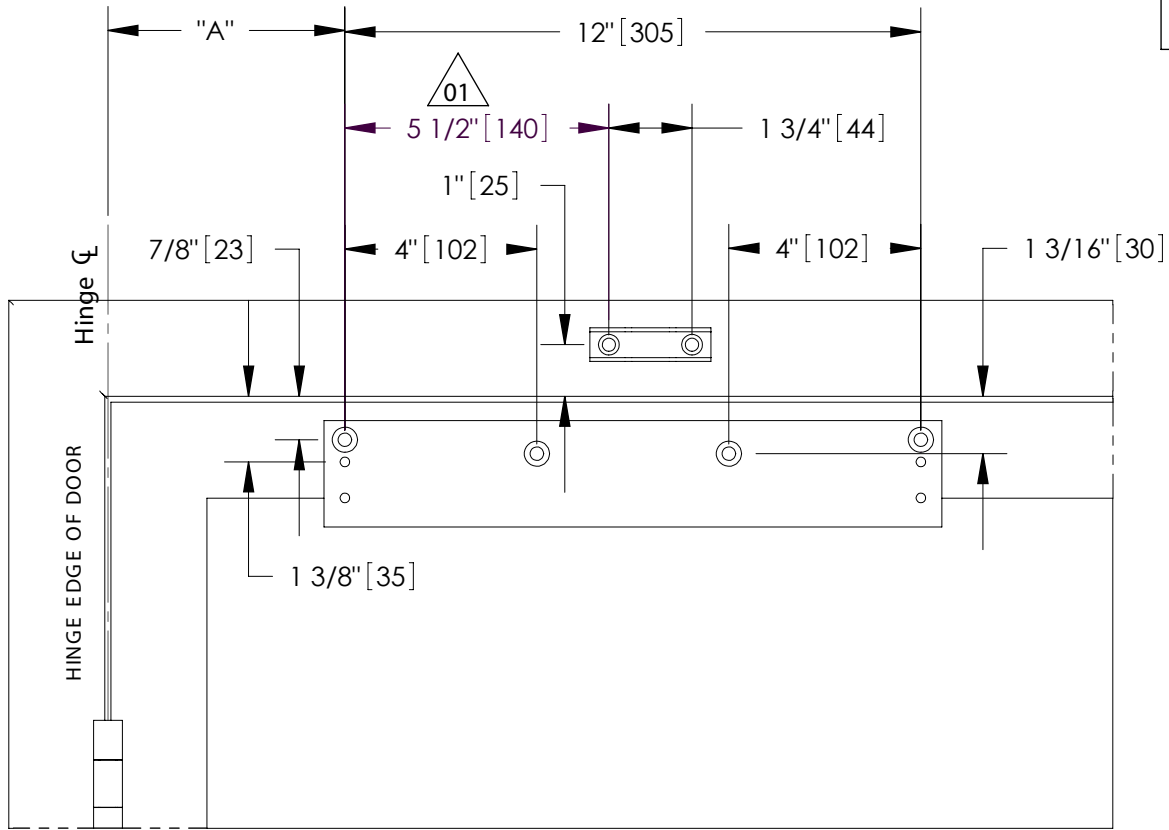

Opening	Dimension "A"
To 100 °	7-1/2" (191mm)
100 ° to 130 °	6" (152mm)
over 130 °	4-1/2" (114mm)

• RIGHT HAND DOOR SHOWN, LEFT HAND OPPOSITE.

01

SCREW PACK INCLUDES:
 4PCS. 1/4-14 X 1-1/2" SELF TAPPING FLAT HEAD WOOD SCREW
 4PCS. 1/4-20 X 1-1/2" SELF TAPPING MACHINE SCREW
 4PCS. 1/4-20 X 7/16" FLAT HEAD MACHINE SCREW



HAGER RESERVES THE RIGHT TO MAKE DESIGN CHANGES WITHOUT NOTICE. CALL HAGER ENGINEERING AT 1-800-325-9995 FOR THE LATEST REVISION DATE OF TEMPLATE.

PRIMARY DIMENSIONS SHOWN IN INCHES, DIMENSIONS IN [] ARE MILLIMETERS.

DRAWN	T Sveitlis	1/16/06
ENG. APPR.	MAM	09/25/06
Q.A.		
TOLERANCES:		
FRACTIONAL: ±0.015"		
ANGULAR: MACH: ± 1° BEND: ±1°		
TWO PLACE DECIMAL: ±0.01"		
THREE PLACE DECIMAL: ±0.004"		
MATERIAL		
FINISH		
DO NOT SCALE DRAWING		

SIZE	DWG. NO.	REV.
A	T-CL00010	01
SCALE: 1:4	WEIGHT:	SHEET 1 OF 1

5918 Narrow Top Rail/RA Mounting Plate Template