

REV.	DESCRIPTION	ECO NO.	DATE
-	INITIAL CHECK IN	NPD14010	3/31/2015

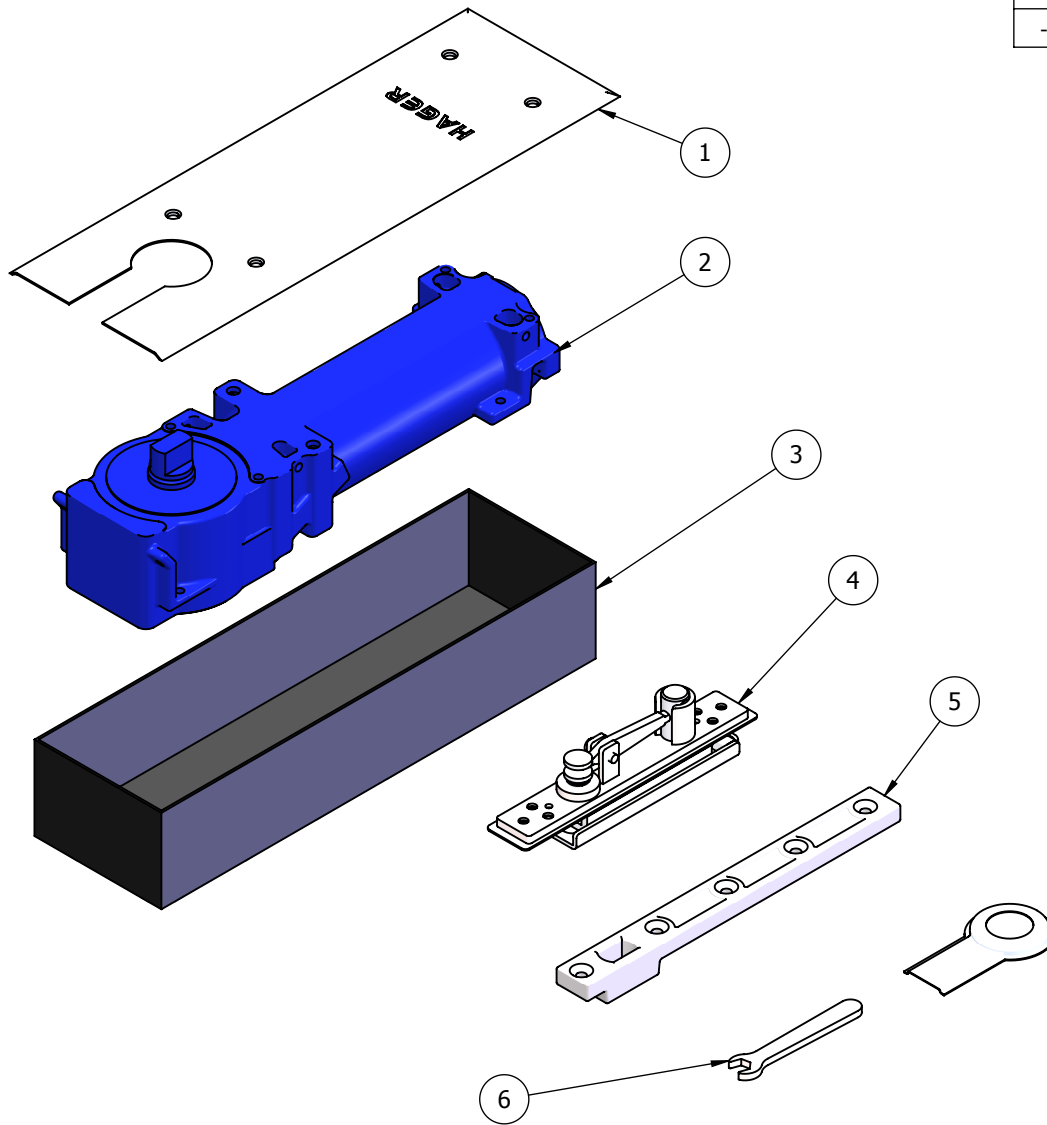

ITEM NO.	FILE NAME	DESCRIPTION	QTY.
1	S-CL00324	Heavy Duty Floor Spring Cover Plate	1
2	S-CL00599	Heavy Duty Floor Spring Body	1
3	S-CL00326	Heavy Duty Floor Spring Mount Box	1
4	S-CL00623	Heavy Duty Floor Spring Top Pivot	1
5	S-CL00337	Heavy Duty Floor Closer Bottom Door Bracket	1
6	S-CL00635	Heavy Duty Floor Spring Misc. Hardware Bag	1
7	T-CL00640	Installation Instructions (Not Pictured)	1
8	N/A	Main Hardware Bag (Not Pictured)	1
8.1	N/A	M6x25mm FPHWS	8
8.2	N/A	M5x25mm FPHWS	3
8.3	N/A	M6-1.0x25mm FPHMS	4
8.4	N/A	M6-1.0x15mm FPHMS	4
8.5	N/A	M5-0.8x15mm FPHMS	3



HAGER RESERVES THE RIGHT TO MAKE DESIGN CHANGES WITHOUT NOTICE. CALL HAGER ENGINEERING AT 1-800-325-9995 FOR THE LATEST REVISION DATE OF TEMPLATE.

PRIMARY DIMENSIONS SHOWN IN INCHES, DIMENSIONS IN [ ] ARE MILLIMETERS.

DRAWN		-	1/1/2008	5800H HEAVY DUTY DOUBLE ACTION FLOOR SPRING	
ENG. APPR.		-	-		
MATERIAL		Material <not specified>		TOLERANCES:	
FINISH		-		FRACTIONAL: ±0.015"	
DO NOT SCALE DRAWING				ANGULAR: MACH: ± 1° BEND: ±1°	
				TWO PLACE DECIMAL: ±0.01"	
				THREE PLACE DECIMAL: ±0.004"	
SIZE	DWG. NO.	REV.			
A	S-CL00600	-			
SCALE: 1:4	WEIGHT: 2019.87	SHEET 1 OF 3			

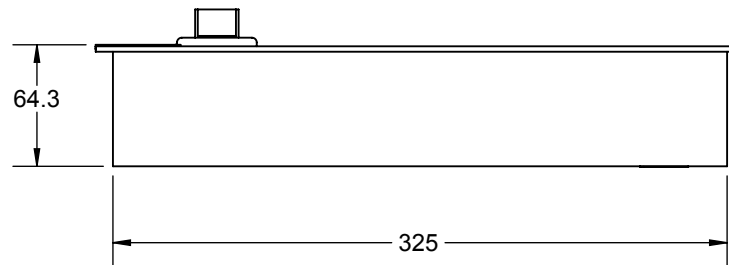
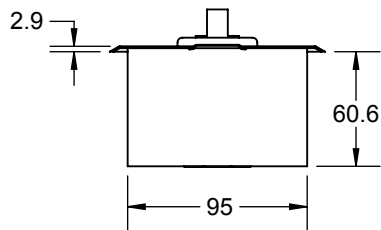
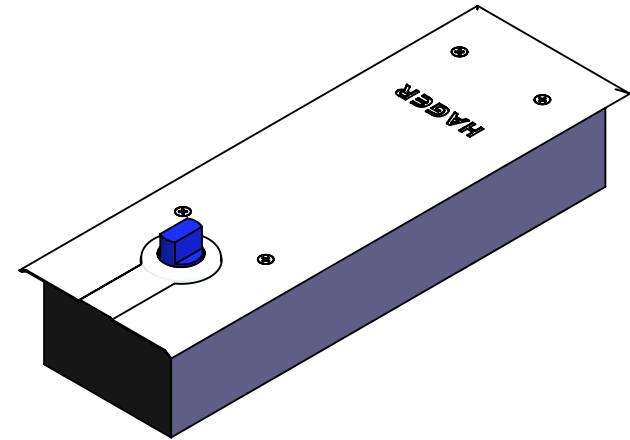
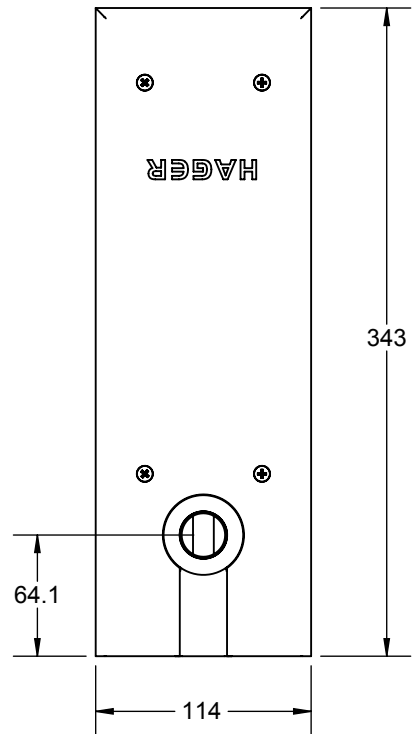

HAGER RESERVES THE RIGHT TO MAKE DESIGN CHANGES WITHOUT NOTICE. CALL HAGER ENGINEERING AT 1-800-325-9995 FOR THE LATEST REVISION DATE OF TEMPLATE.

PRIMARY DIMENSIONS SHOWN IN INCHES, DIMENSIONS IN [ ] ARE MILLIMETERS.

	DRAWN	RTHOMP	5/20/2011
	ENG. APPR.	-	-
MATERIAL	STEEL AND ALUMINUM		
FINISH	BRUSHED		
	TOLERANCES: FRACTIONAL: $\pm 0.015"$ ANGULAR: MACH: $\pm 1^\circ$ BEND: $\pm 1^\circ$ TWO PLACE DECIMAL: $\pm 0.01"$ THREE PLACE DECIMAL: $\pm 0.004"$		
DO NOT SCALE DRAWING			

5800F  
DUAL ACTION FLOOR CLOSER

SIZE	DWG. NO.	REV.
A	S-CL00600	-
SCALE: 1:4	WEIGHT: 1295.41	SHEET 2 OF 3

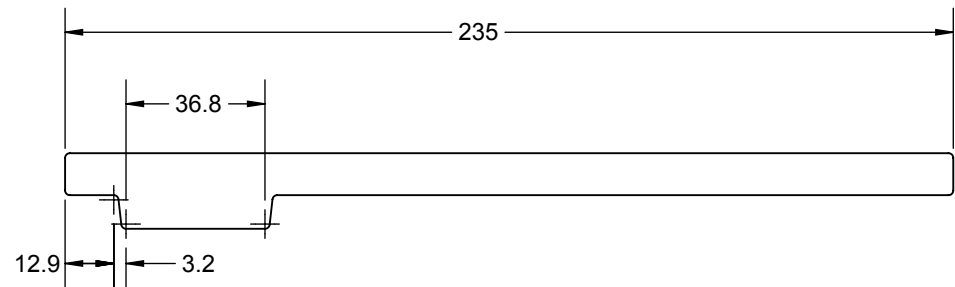
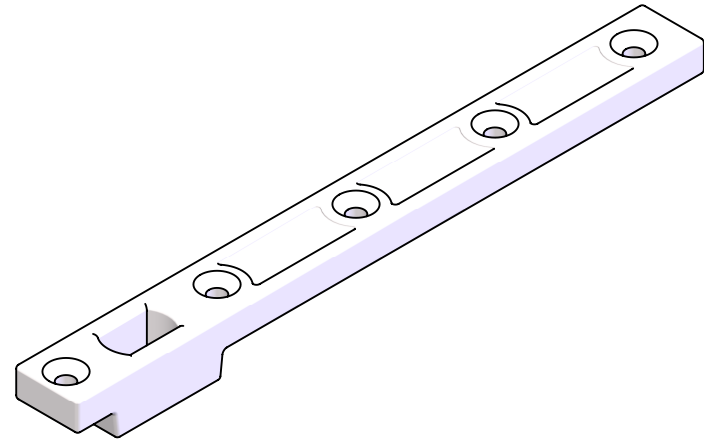
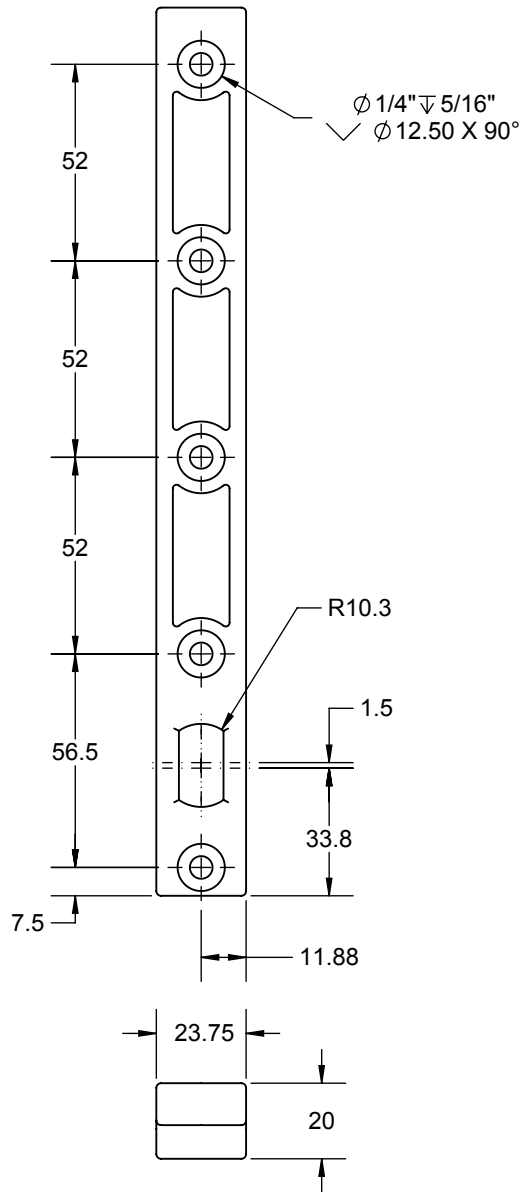

HAGER RESERVES THE RIGHT TO MAKE DESIGN CHANGES WITHOUT NOTICE. CALL HAGER ENGINEERING AT 1-800-325-9995 FOR THE LATEST REVISION DATE OF TEMPLATE.

PRIMARY DIMENSIONS SHOWN IN INCHES, DIMENSIONS IN [ ] ARE MILLIMETERS.

MATERIAL	Material <not specified>	
FINISH	-	
DO NOT SCALE DRAWING		

DRAWN	-	1/1/2008
ENG. APPR.	-	-
Q.A.		
TOLERANCES:		
FRACTIONAL: $\pm 0.015"$		
ANGULAR: MACH: $\pm 1^\circ$ BEND: $\pm 1^\circ$		
TWO PLACE DECIMAL: $\pm 0.01"$		
THREE PLACE DECIMAL: $\pm 0.004"$		

5800H HEAVY DUTY DOUBLE ACTION FLOOR SPRING		REV.
SIZE	DWG. NO.	-
<b>A</b>	S-CL00600	-
SCALE: 1:2	WEIGHT: 2019.87	SHEET 3 OF 3