

REV.	DESCRIPTION	ECO NO.	APPROVED BY	DATE
-	INTIAL CHECK IN	OT19001		5/16/2019

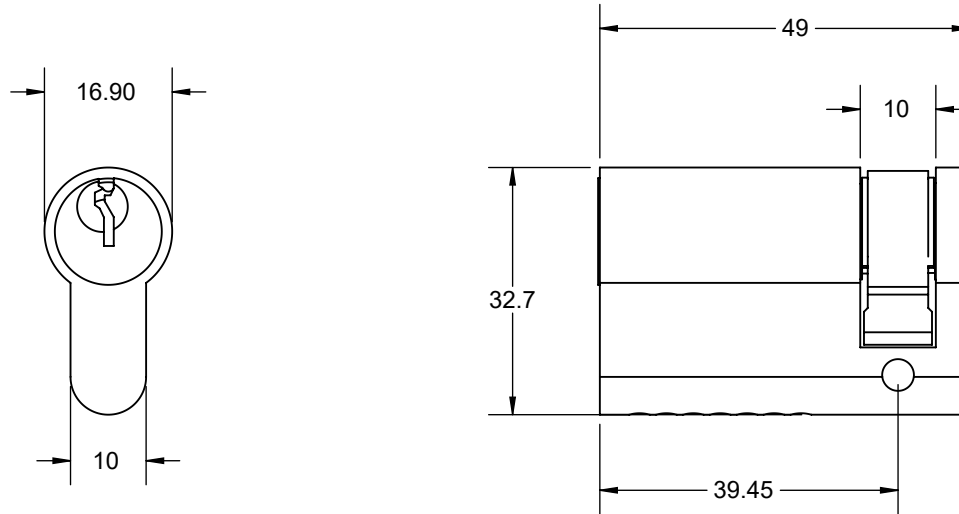

NOTE:
DRILLED SEVEN PIN
HAGER 'H1' KEYWAY



PROPRIETARY & CONFIDENTIAL
THE INFORMATION CONTAINED
IN THIS DRAWING IS THE SOLE
PROPERTY OF HAGER
COMPANIES. ANY REPRODUCTION
IN PART OR AS A WHOLE WITHOUT
THE WRITTEN PERMISSION OF
HAGER COMPANIES IS PROHIBITED.

HAGER RESERVES
THE RIGHT TO
MAKE DESIGN
CHANGES
WITHOUT NOTICE.
CALL HAGER
ENGINEERING AT
1-800-325-9995
FOR THE LATEST
REVISION DATE
OF TEMPLATE.

	DRAWN	DRS	7/16/2014
	ENG. APPR.	-	-
MATERIAL	BRASS		
FINISH	AS SPECIFIED		
DO NOT SCALE DRAWING			
		TOLERANCES: FRACTIONAL: $\pm 0.015''$ ANGULAR: MACH: $\pm 1^\circ$ BEND: $\pm 1^\circ$ TWO PLACE DECIMAL: $\pm 0.01''$ THREE PLACE DECIMAL: $\pm 0.004''$	

		3000-50H - H1 Euro Half Cylinder - Hager Keyway	
SIZE	DWG. NO.	REV.	
A	S-CK00058	-	
SCALE: 1:1	WEIGHT: 148.58	SHEET 1 OF 2	

REV.	DESCRIPTION	ECO NO.	APPROVED BY	DATE
-	See 50H H1	-	-	-

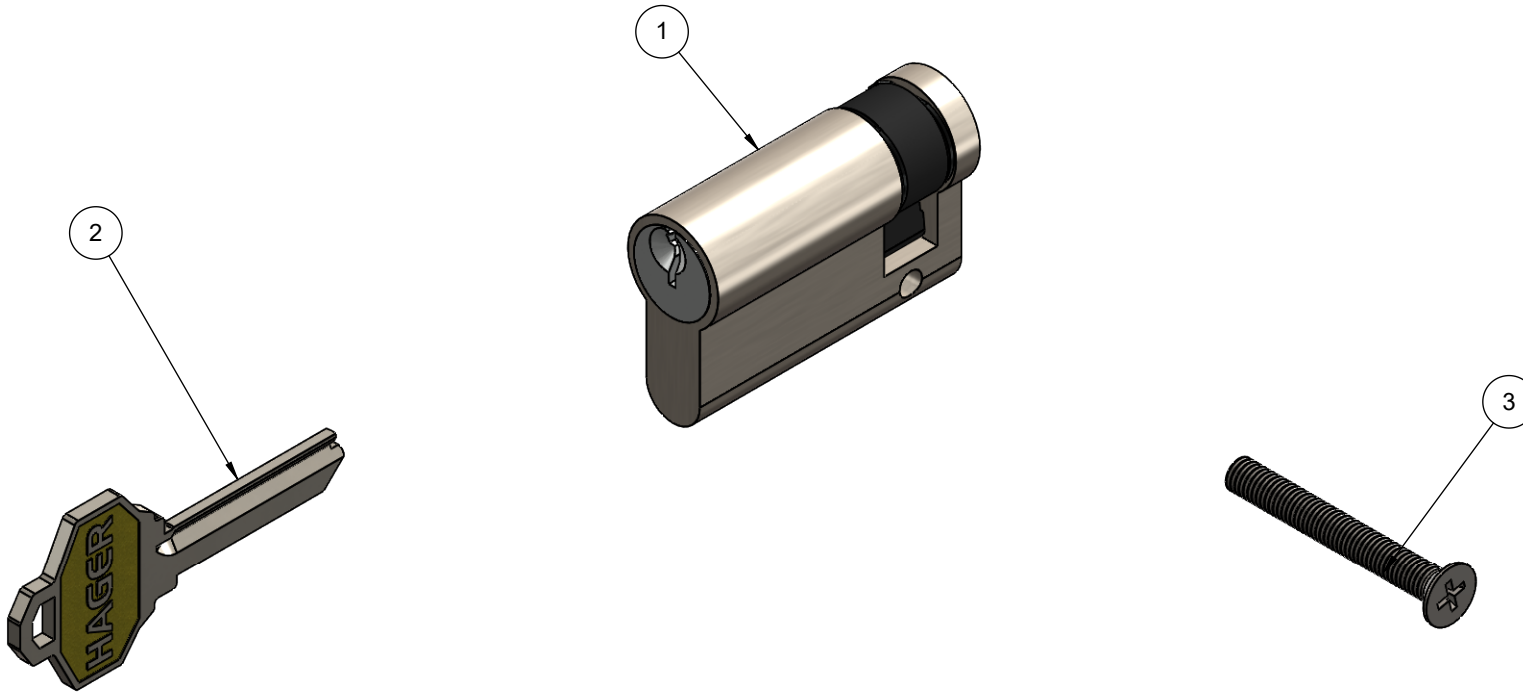

ITEM NO.	FILE NAME	DESCRIPTION	QTY
1	S-CK00018	EURO H-SERIES CYLINDER	1
2	S-LS01787	HAGERH1 KEY	1
3	flat head screw_am		1

NOTES:
PACKAGED IN PLAIN WHITE BOX

 PROPRIETARY & CONFIDENTIAL THE INFORMATION CONTAINED IN THIS DRAWING IS THE SOLE PROPERTY OF HAGER COMPANIES. ANY REPRODUCTION IN PART OR AS A WHOLE WITHOUT THE WRITTEN PERMISSION OF HAGER COMPANIES IS PROHIBITED.	HAGER RESERVES THE RIGHT TO MAKE DESIGN CHANGES WITHOUT NOTICE. CALL HAGER ENGINEERING AT 1-800-325-9995 FOR THE LATEST REVISION DATE OF TEMPLATE.	DRAWN	DRS	7/16/2014	3000 - 50H Euro Half Cylinder - Hager Keyway Box Contents	
		MATERIAL	BRASS	ENG. APPR.		-
		FINISH	AS SPECIFIED	Q.A.		
		DO NOT SCALE DRAWING		TOLERANCES: FRACTIONAL: $\pm 0.015"$ ANGULAR: MACH: $\pm 1^\circ$ BEND: $\pm 1^\circ$ TWO PLACE DECIMAL: $\pm 0.01"$ THREE PLACE DECIMAL: $\pm 0.004"$		
		SIZE	DWG. NO.		REV.	
		A	S-CK00058		-	
		SCALE: 1:1	WEIGHT: 148.58		SHEET 2 OF 2	