

NOTE 1: TEMPLATE NOT TO SCALE.  
 NOTE 2: DIMENSIONS IN [ ] ARE IN MILLIMETERS.

# 313L ANTI-VANDAL PULL INSTALLATION INSTRUCTIONS

## 313L LHR PULL WITH 4500 SERIES EXIT DEVICE

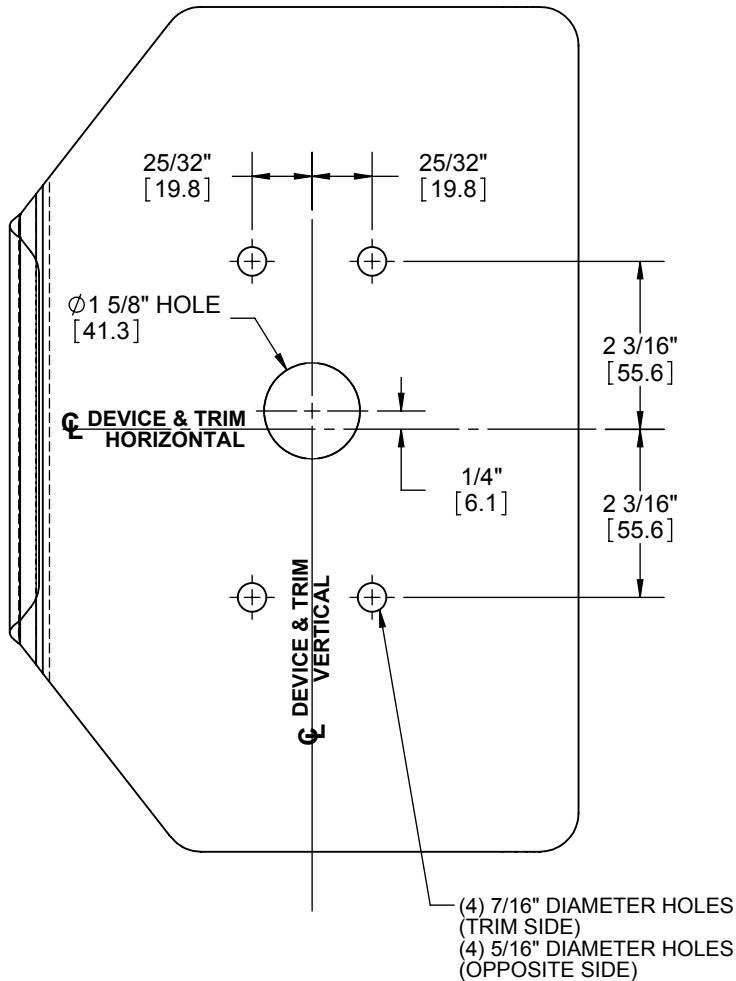

**STEP 1.**  
 PREPARE PUSH SIDE OF THE DOOR FOR EXIT DEVICE. SEE EXIT DEVICE TEMPLATE FOR DOOR PREPARATION DETAIL.

**STEP 2.**  
 PREPARE PULL SIDE OF DOOR FOR PULL.

- TRANSFER VERTICAL AND HORIZONTAL DEVICE CENTERLINES FROM PUSH SIDE OF DOOR TO PULL SIDE.
- LOCATE AND PREP HOLES USING DIAGRAM ABOVE.

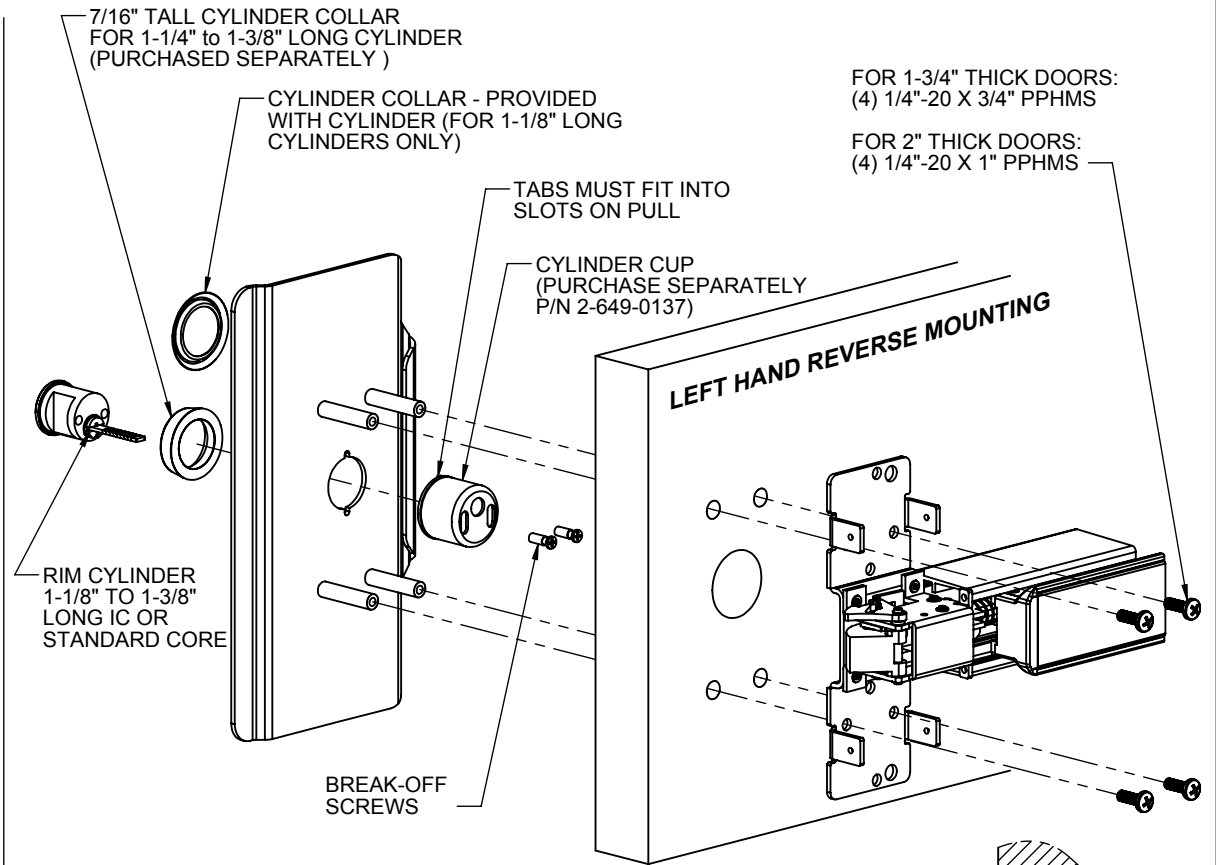

**STEP 3.**  
 SECURE RIM CYLINDER TO PULL USING CYLINDER CUP AND SUPPLIED BREAK OFF SCREWS. USE PLIERS TO BREAK OFF EXCESS, BEING CAREFUL NOT TO BREAK OFF TOO MUCH.

**STEP 4.**  
 PLACE TRIM ON DOOR AND CUT CYLINDER TAILPIECE SO IT PROJECTS 3/8" +/- 1/16" OUT OF DOOR. IF TAILPIECE IS TOO LONG, MEASURE AND CUT OFF AT CLOSEST BREAK OFF LINE.

**STEP 5.**  
 SECURE PULL AND EXIT DEVICE USING THE 4 MOUNTING SCREWS.

