

# **Installation and Service Manual 8300 Series Swing Door Operators**



The manufacturer's specifications for this product require the installation to be approved by an AAADM certified inspector.

## Owner Information & Table of Contents

The Hager Series 8300 Operator has been carefully designed, built, and tested to provide years of service.

The life of the operator package is directly related to how carefully the installation is accomplished and how accurately the instructions are followed. Installation of this operator package should be done by properly trained and knowledgeable installers with knowledge of local code requirements and the requirements of ANSI A156.10 Standards for Power Operated Pedestrian Doors and A156.19 Standards for Low Energy and Power Assisted Pedestrian Doors. The authorized service / installation dealer must perform all measurements for forces, speeds, and times to insure proper and safe operation.

Hager Companies is not responsible for improperly adjusted or maintained automatic doors or activation / safety systems and assumes no responsibility for damages caused by automatic door systems that have not been properly installed, tested, and adjusted.

### OWNER INFORMATION TO BE PROVIDED BY THE DISTRIBUTOR / INSTALLER

- After the installation instruct the owner on the safe operation of the door.
- Location and proper use of the power switches.
- Location of the main cutoff breaker.
- Necessary warnings not covered in general instructions.
- Owner’s Manual and Daily Safety Checklist.
- Phone number(s) for the local servicing dealer.
- What to do in the event that a dangerous situation should occur and how to shut the doors down and call for service.

**READ INSTALLATION INSTRUCTIONS BEFORE INSTALLING.** The sequence of installation and adjustment is in order; however some sections will not apply. Review this instruction manual and determine those sections that do apply. Be sure all doors swing freely and clear all objects before attaching arms. Special attention needs to be given to installations with parallel and slide arms when an adjacent wall is perpendicular to the door frame.

### **TABLE OF CONTENTS**

<b>OWNER INFORMATION &amp; TABLE OF CONTENTS.....</b>	<b>2</b>
<b>PRODUCT DESCRIPTION, SPEC &amp; TOOLS REQUIRED.....</b>	<b>3</b>
<b>HEADER INSTALLATION.....</b>	<b>4-5</b>
<b>HANDING.....</b>	<b>6</b>
<b>PUSH ARM INSTALL.....</b>	<b>7</b>
<b>PULL ARM INSTALL.....</b>	<b>8</b>
<b>MECHANICAL STOP ADJUSTMENT.....</b>	<b>9</b>
<b>A/C WIRING.....</b>	<b>10</b>
<b>CONTROL BOARDS.....</b>	<b>11</b>
<b>COMMISIONING.....</b>	<b>12</b>
<b>PAIRED OPERATORS.....</b>	<b>13</b>
<b>FIRE RATED APPLICATIONS.....</b>	<b>14</b>
<b>SW2 DIP SWITCH SETTINGS.....</b>	<b>15</b>
<b>J4, J5, AND J6 TERMINAL INPUTS.....</b>	<b>16</b>
<b>WIRING DIAGRAM.....</b>	<b>17</b>
<b>TROUBLE SHOOTING.....</b>	<b>18</b>

## PRODUCT DESCRIPTION & SPECIFICATIONS

The Hager 8300 series low energy auto-operators offer state-of-the-art micro-processed controllers with electro-mechanical drive. The unique slim-line design offers non-handed operation, full mechanical stops, and numerous interface options for sensors, push-plates, fire alarms and electric locks. The unit includes onboard diagnostics to simplify troubleshooting when needed.

Power Supply	115 VAC (+6%, -10%) 60Hz		
Power Consumption	100W		
Current Consumption	1A		
Motor	24 VDC Permanent Magnet With Belt Driven Encoder		
Header Dimensions	20 3/4" x 4 1/8" x 4 3/4" (l x w x d)		
Fused Protection	3.5A Fuse (F1 located on I/O Board)		
Weight	22 lbs Per Operator Assembly		
Ambient Operating Temperature	-4 to 131° F		
Ingress Protection	IP23		
Maximum Door Weight		Push Arm	Pull Arm
	36" Door	438 lbs	342 lbs
	42" Door	328 lbs	256 lbs
	44" Door	299 lbs	234 lbs
	48" Door	254 lbs	198 lbs
24 VDC Accessories Power Supply	24 VDC / I A. Max		
24 VDC Electric Lock Power Supply	24 VDC / I A. Max		
Adjustable Speeds & Timers	Opening Speed Closing Speed Hold Open Time Closing Speed with power off		
Standard Selector Switch Functions	Automatic Hold Open Manual (Off)		
Standard Control Outputs	Malfunction Alarm Electric Lock Relay 24VDC Accessories Power Supply Door Status		
Standard Control Inputs	Interior Activation Exterior Activation Emergency Shutdown Alarm Output Safety Device Input Secondary Activation		

## Header Installation

1. Prep door and frame per drawing S-EA00258.
2. Remove operator drive module from header back-plate.
3. Mount header back-plate to the top door frame.
  - **Push side mounting:** Back-plate should be flush with bottom of door frame.
  - **Pull side mounting:** Back-Plate should be mounted 1.5" up from bottom door frame.
  - Back-plate should overlap each jamb tube by 1.5"
  - **Refer to page 13 for fire rated door applications.**
4. Re-install operator drive module per handing charts on page 6.

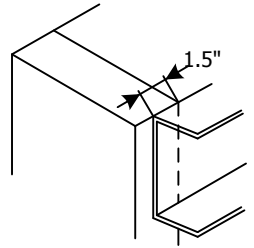

**Push Arm (35mm Spindle)  
Hollow Metal Frame (5/8" Stop Height)**

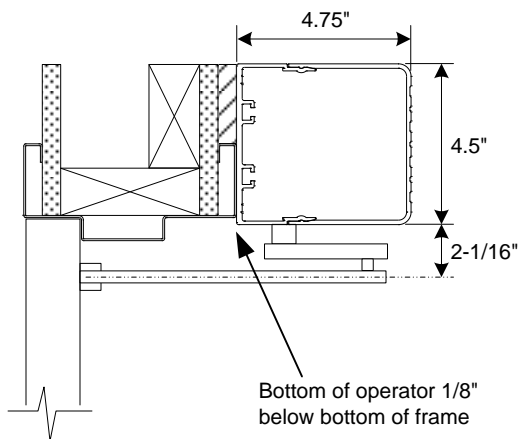

**Pull Arm (20mm Spindle)  
Hollow Metal (5/8" Stop Height)**

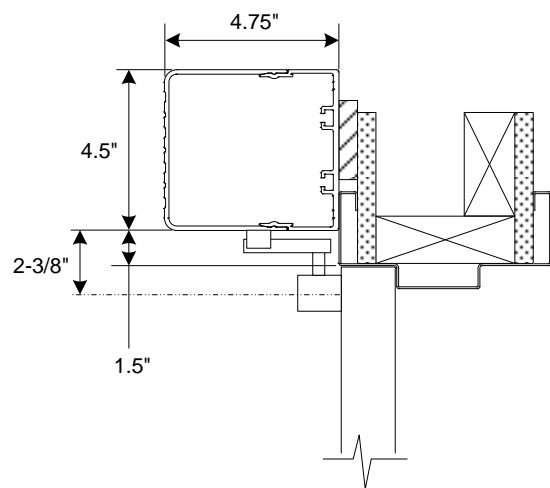

**Push Arm (35mm Spindle)  
Aluminum Frame (1/2" Stop Height)**

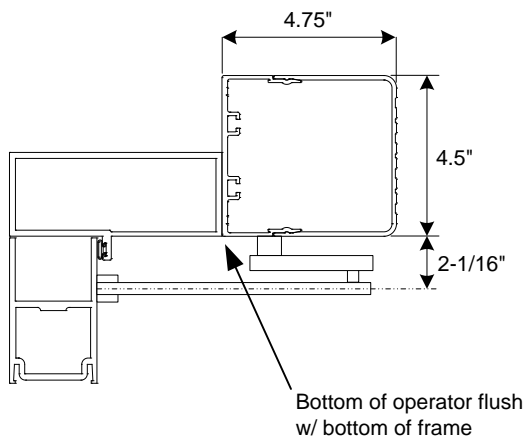

**Pull Arm (20mm Spindle)  
Aluminum (1/2" Stop Height)**

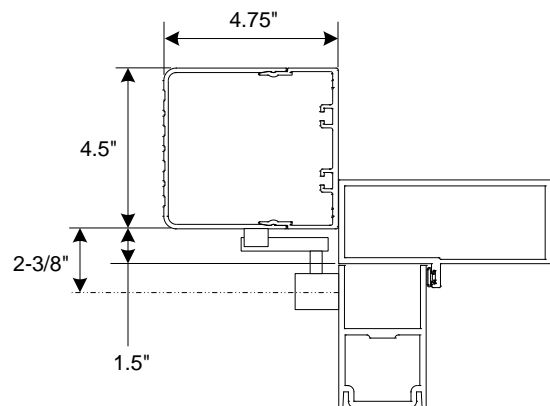

## Header Installation (Cont)

The operator is mounted to a short aluminum "drive" plate that is held into the header by 5 mounting screws. Four (4) of the screws secure the drive plate. One (1) screw is used to locate the drive plate using a 'keyhole' configuration. The keyhole allows for easy removal of the drive plate without the need to loosen the screw. Removing the four (4) screws allows the drive plate and operator to be removed from the header and rotated 180 degrees to change from a push to a pull or vice versa.

1. Loosen the four (4) mounting screws using a 5mm hex wrench and slide each one off the drive plate.

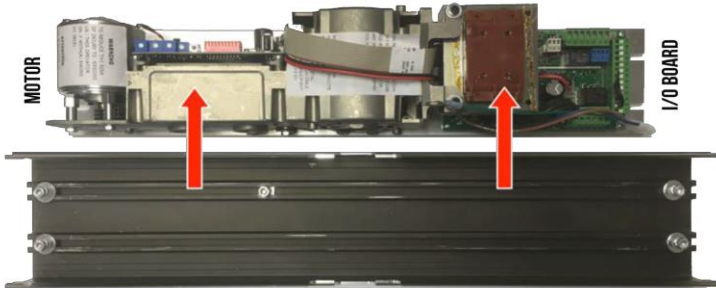
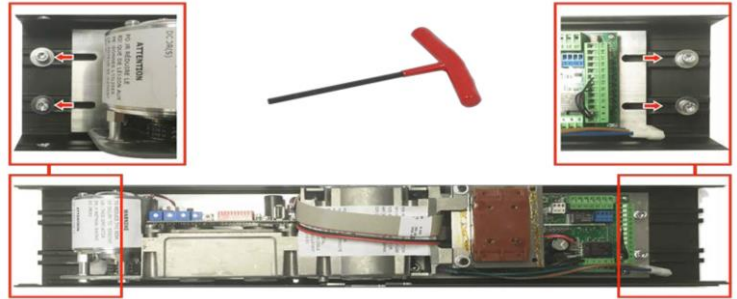

2. Remove drive plate by shifting to the left and lifting the drive plate off the locating screw.

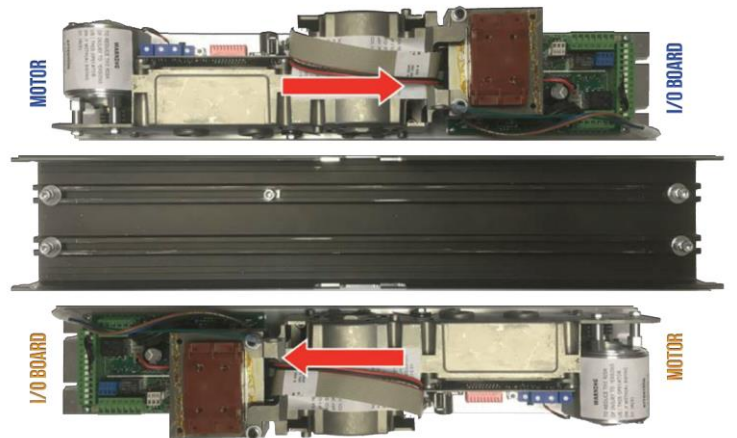

3. After installing the back-plate to the frame, mount the drive module to the back-plate. See page 6 for operator handing and arm type.

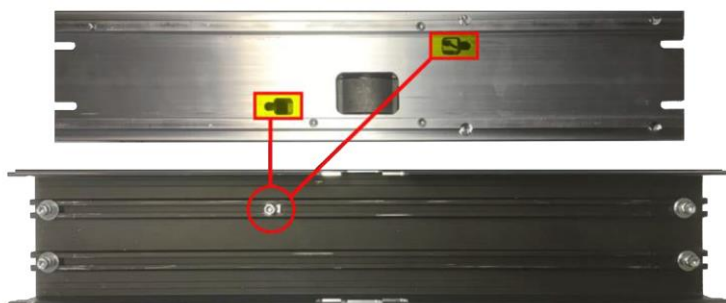

Key slot configuration and location screw mounted to back-plate.

## Handing

Operator is non-handed. Handing is determined by operator mounting orientation inside header.

- Push = I/O Board Towards Hinge Jamb (and SW2 Dip Switch #2 "OFF", see page 6)
- Pull = Round Motor Towards Hinge Jamb (and SW2 Dip Switch #2 "ON", see page 6)

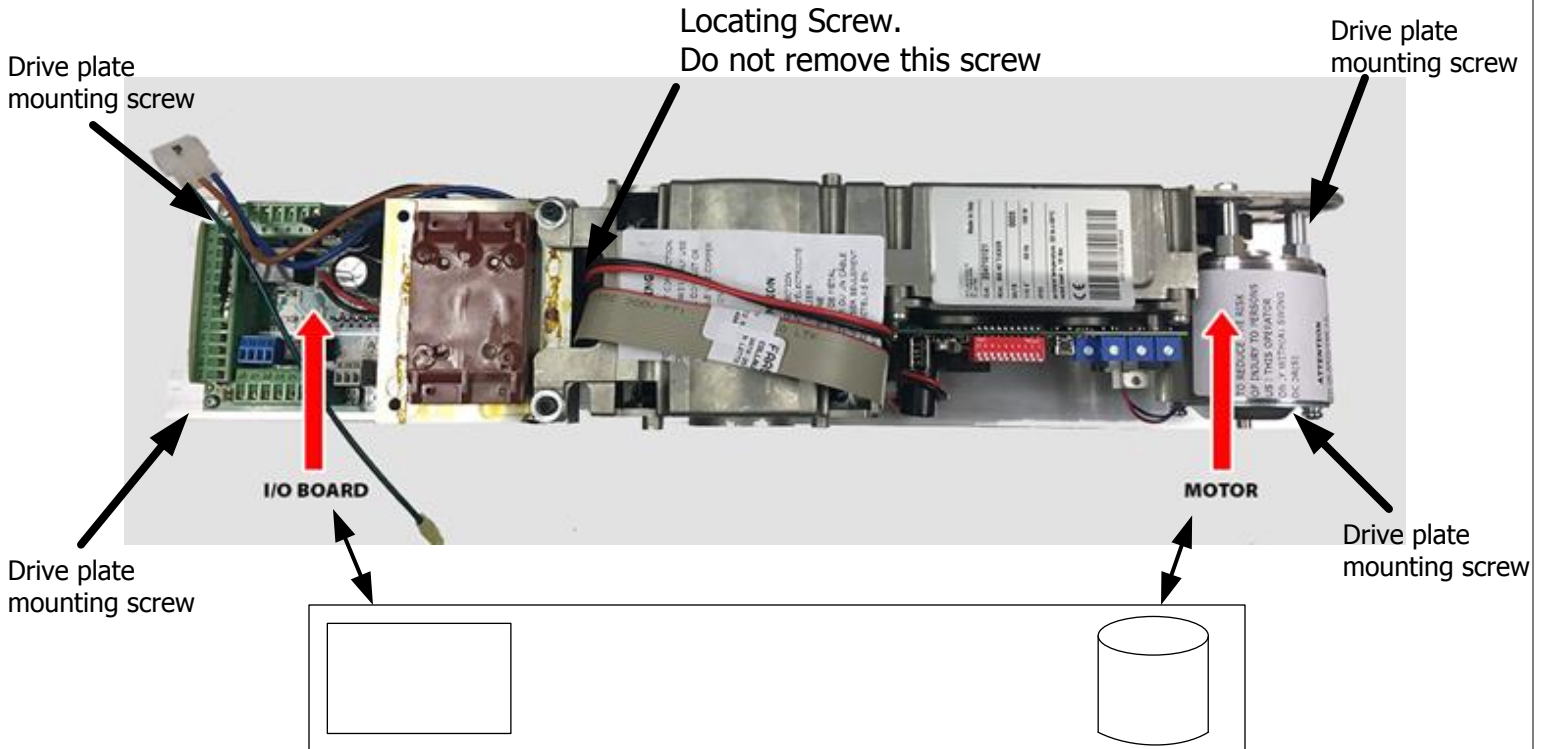

### PUSH SIDE MOUNTING WITH STANDARD ARM

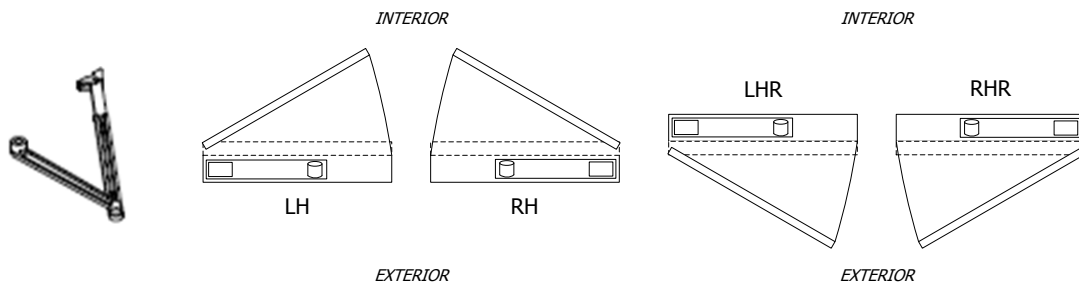

### PULL SIDE MOUNTING WITH TRACK ARM

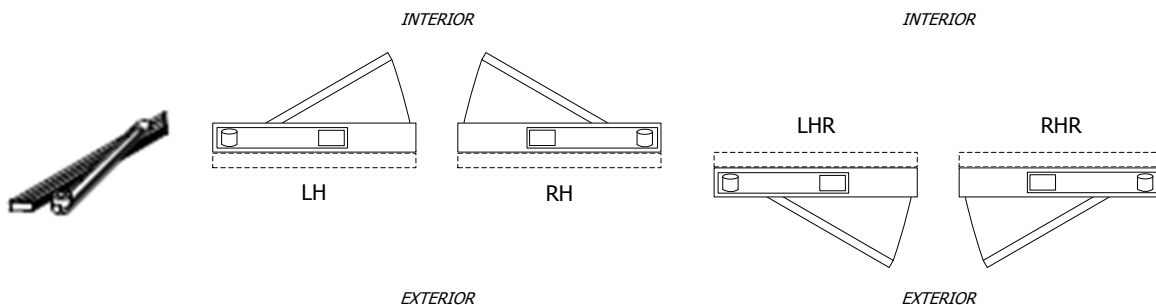



## Push Arm Installation

All push arms come standard with 35mm spindle. Other spindle sizes available, see below.

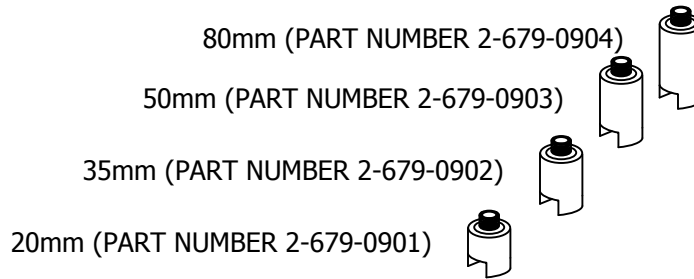

1. Detach the secondary and primary arms.
2. Attached the spindle to the primary arm (make sure to install the spindle mounting bolt).
3. Attach the primary door arm approx. 20 degrees past perpendicular and towards the closing direction as shown. If more spring tension is desired, simply increase the mounting angle to greater than 20 degrees so it results in increased preload. Adjust the secondary telescopic arm to the prescribed length according to chart:

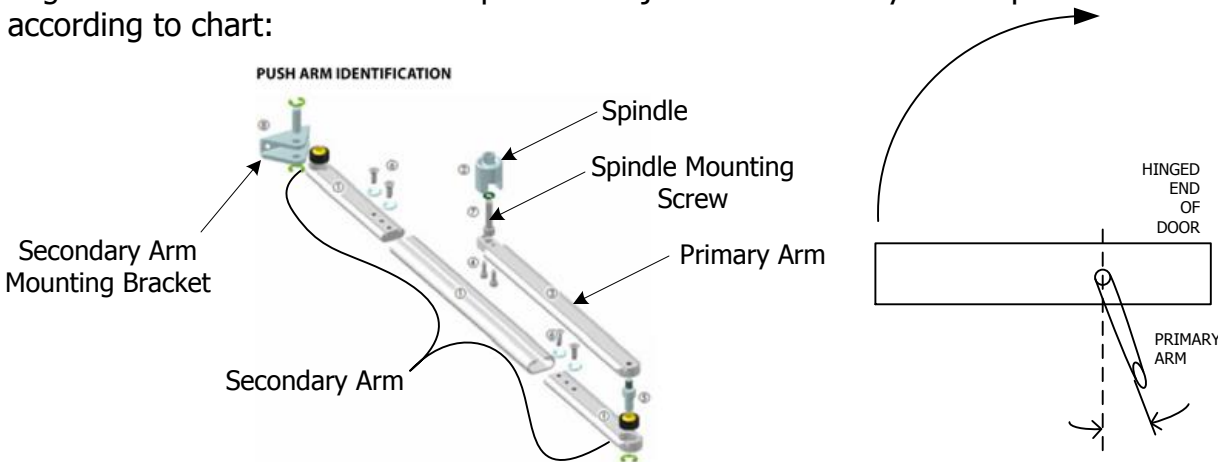

4. Adjust the secondary telescopic arm to the prescribed length according to chart:

- Before installing the secondary arm, it is easiest to lay the arm out on a flat surface and adjust its size as required.

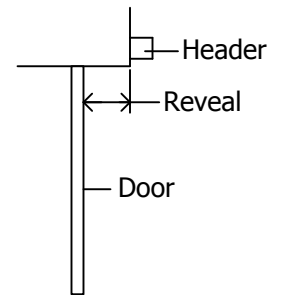

Reveal	Hinge Hung 'X' Dim.	Center Pivot 'X' Dim.
0"	13"	16"
1"	14"	17"
2"	15"	18"
3"	16"	19"
4"	17"	20"
5"	18"	21"
6"	19"	
7"	20"	
8"	21"	

**DEEPER REVEAL REQUIRES ARM EXTENSION**

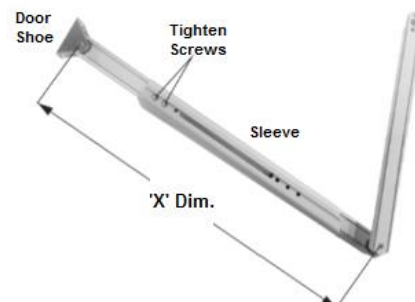

## Push Arm Installation (Cont.)

**3.** Attach the secondary arm mounting bracket to the door. The centerline of the bracket should be at 13-1/2" in from the inside face of the hinge jamb when using butt hinges on the door, and 16" when using a center pivoted door.

**4.** Rotate the primary arm in the opening direction as to reach the pivot point of the secondary. Attach the arms together with the hardware provided.

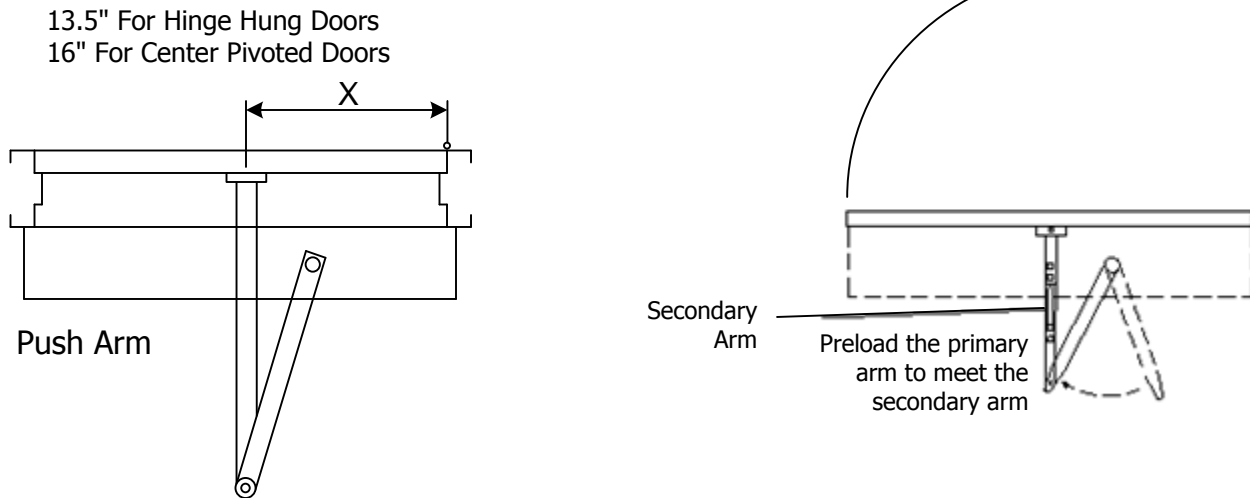

## Pull Arm Installation

**1.** Install the slide track assembly at the pull side of the door at the proper location from the hinge end of the door as shown below:

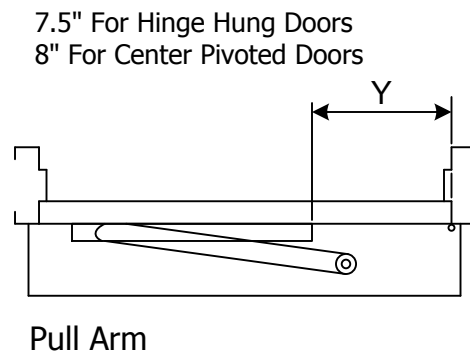

**2.** To install the pull arm, the operator must be powered to the full open position, as it is not possible to install the arm in the closed position as to allow proper preload.

**3.** Power the door to the open position through the use of the hold-open switch on the side of the header. It may be necessary to first execute a "setup" on the operator prior to doing this. See page 11 for commissioning instructions.

**4.** Once the operator is rotated to the full open position, manually move the door to the desired full open position and insert the slide track guide block into the track. When completed, the end caps to the track can be installed.



## Mechanical Stop Adjustments

After the operator is fully installed, adjust the mechanical stops as shown below.

- **IMPORTANT** – This step may be optional depending on your application
- **CAUTION** – DO NOT REMOVE THE STOPS
- The mechanical stops are located on the top or bottom of the operator, depending on the door handing.
- The stops are default set to maximum opening and closing angles.
- To adjust the stops, loosen the bolts indicated below with a 5/32" wrench or pliers and slide the stop in the track to the desired stop location.
  - It is recommended to place the door in the desired open or closed position then slide the required stop until it hits the internal stop point screw.

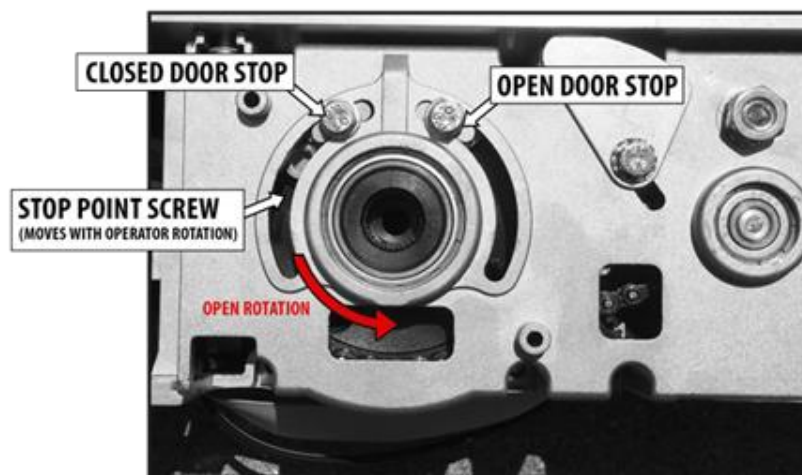

## A/C WIRING

### **Warning:**

Ensure all incoming electrical power is shut off before proceeding with any wiring to Hager 8300 operator. Use only with wire harness provided; failure to do so may result in damage to equipment or personal harm as well as voiding the warranty.

- Connect the main power to the Black / White / Green connector on the back-plate.
  - Main power supply: 120VAC, 15A, Single Phase, 60hz.
  - Attach the incoming 120VAC line to the wiring provided in the header shown below.
- DO NOT TURN POWER ON until all remaining wiring has been completed.



BLACK: 120VAC Power

WHITE: Neutral

GREEN: Ground

- Upon applying power, observe the adjustment board LED's (page 10).
  - NORMAL OPERATION: DL3 will come on steady and then begin flashing after a few seconds.
  - FAULTY OPERATION: DL2 will be flashing red. This indicates...
    - An error condition exists – correct as necessary
    - Operator requires commissioning – see page 11.

## Control Boards

- Before proceeding, familiarize yourself with the operator control boards below.

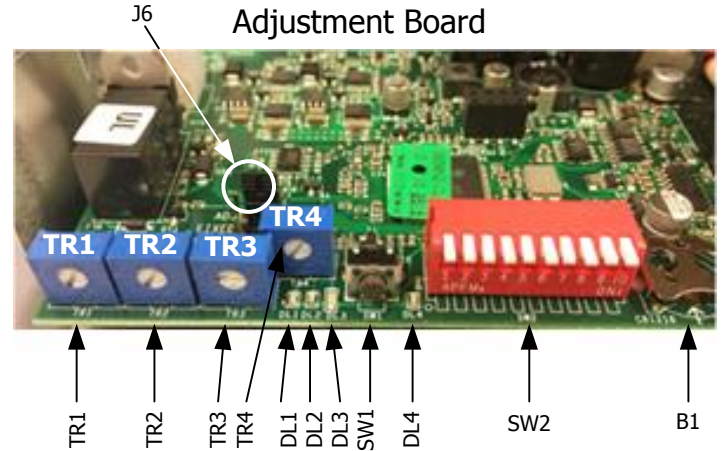
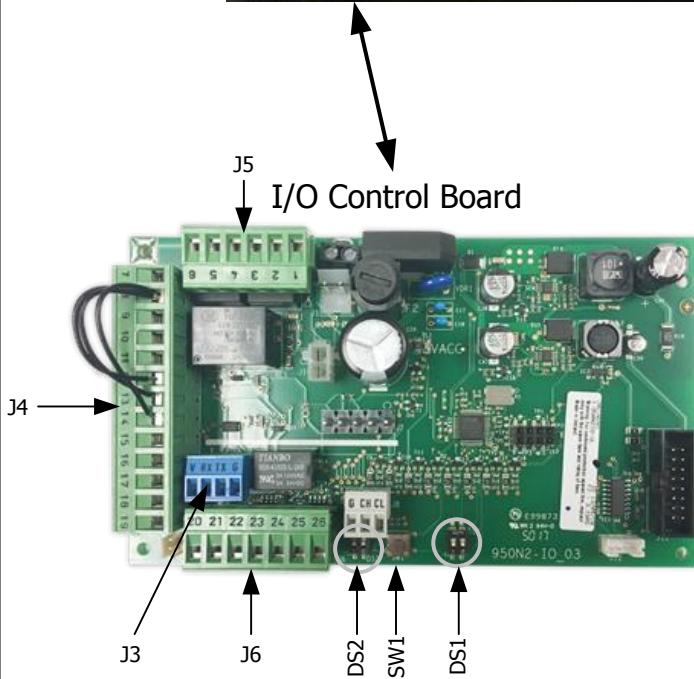

<b>I/O Control Board</b>	
J5	Relay Terminal Strip *
J4	Activation Terminal Strip *
J3	Programmer Terminal Strip **
J6	Auxiliary Terminal Strip *
DS2	NOT USED
SW1	Commisioning Button
DS1	NOT USED

<b>Adjustment Board</b>	
J6	Unpowered Closing Speed Jumper ***
TR1	Opening Speed Adjustment
TR2	Closing Speed Adjustment
TR3	Hold Open Time Adjustment
TR4	Unpowered Closing Speed Adjustment ***
DL1	LED - Green
DL2	LED - Red
DL3	LED - Blue
SW1	Parameter Change Switch
DL4	LED - Yellow
SW2	10 Function Dip Switch ****
B1	Programmer Setting Battery *****

\* See Page 15 for terminal strip input usages.  
\*\* Only used with Optional Hager programmer.

\*\*\* Enabled when jumper J6 'ON' (Default Enabled).  
\*\*\*\* See Page 14 for SW2 dip switch settings.  
\*\*\*\*\* Required to maintain programmed settings.

## Commissioning

The commissioning step allows the operator to learn the door weight, motion, and stop location.

**This step must be performed on all new installations or anytime the operator stroke is altered in any way.**

To begin commissioning...

1. Ensure main power is on.
2. Verify the adjustment board dip switches SW2 are set as desired.
3. At the I/O control board, press the SW1 button for approximately 5 seconds. When the red LED (DL2) on the Adjustment Board begins flashing rapidly, release the button.
  - If the red LED (DL2) does not start flashing, verify that you are pressing the SW1 button on the I/O control board and not the SW1 button on the Adjustment Board.
4. The door will slowly open, recycle partially, close and re-open.
5. Do not interrupt the process and do not move the door manually during this time.
6. If the door does not open and the red LED (DL2) is flashing slowly, verify that the motor is plugged in properly at the control board. Correct as necessary.
7. Once commissioning is complete, the door will close and the LED will go out.
8. Commissioning complete.
9. Upon commissioning completion, activate the door to open and ensure all performance is acceptable.
  - Adjust opening/closing speeds and hold open time as required.
  - DL4 will illuminate yellow anytime a change has been made to the control, such as speed or time adjustment. Momentarily press Adjustment Board SW1 to acknowledge the change and extinguish the yellow LED.
  - If speeds or hold open time are changed, a re-learn is not required.

### Notes:

- A re-learn is not required following a main power recovery.
- Speed and time adjustment changes will not take effect until the door closes fully after the adjustment has been made.
- Additional adjustments are available with the Hager programmer (part number 2-679-0907)

## Paired Operators

- When wiring controls for use as a simultaneous pair, all required inputs need to be sync'd (connected) between Door #1 and Door #2 (shown as dotted lines in below diagram).
- Example shown below: Push plates are connected to inputs 8, 10 and 11 at door #1 and are connected via sync line to Door #2.
- When using pairs of controls, inputs 12, 13 and 14 may be sync'd to each other, OR each control may have it's own jumpers installed. If any of these inputs are required for the application, the jumper will be removed for the respective input – in place of the jumper, a N.C. switching circuit will connected to Door #1, and a sync line will be connected to Door #2.
- For simultaneous pairs, Hager provides a dual harness standard for the On-Off-Hold switch. Each plug-in connector for the control is wired in parallel to the On-Off-Hold switch located in the header end-cap. One switch will control both doors.
- All control adjustments (speed & time delay) must be made independently at each control.
- All dipswitches at each control must be set independently and must match between controls.
- When using the optional programmer, settings must be made independently at each control and must match between controls.

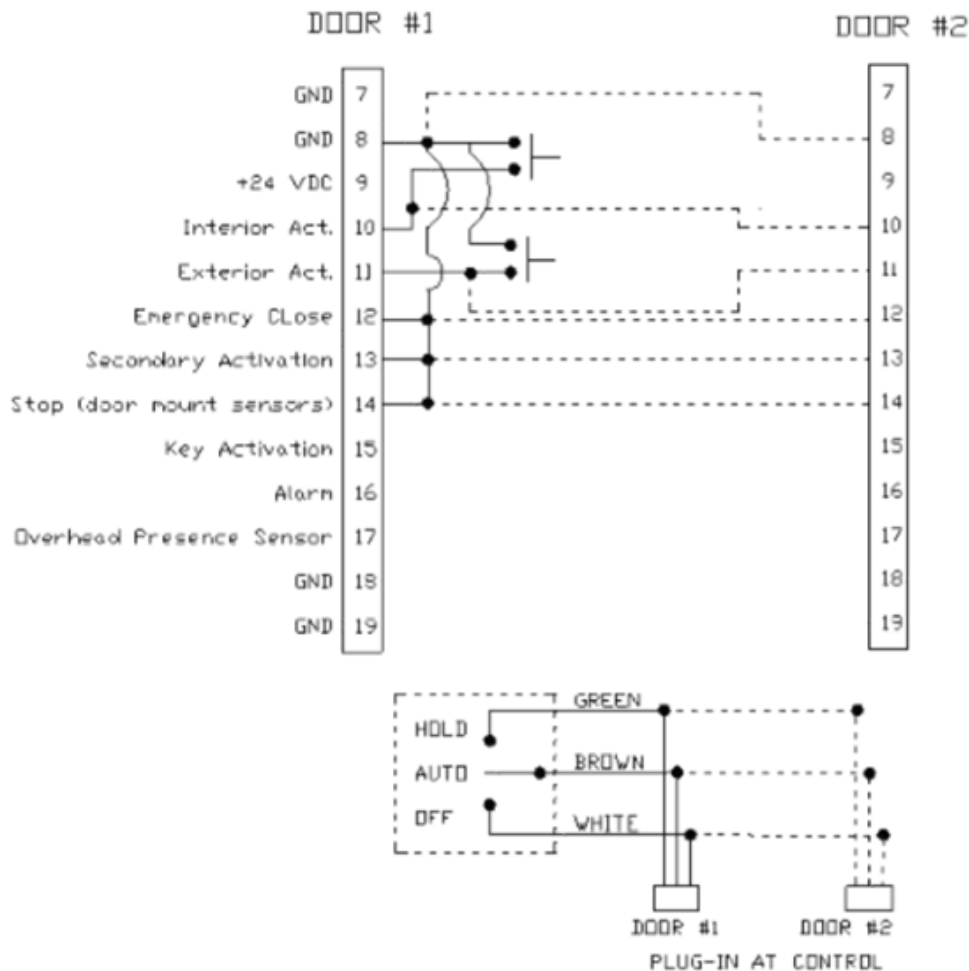



## Fire Rated Applications

Perform the installation according to the instructions outlined in this manual. Additionally, ensure the following conditions have been met:

- When attaching the door arm to the door, use steel binding posts (Sex Bolts) to attach. Do NOT use sheet metal screws into the face of the door. The door arm bracket must be through-bolted.

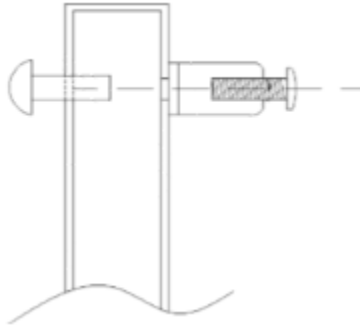

- When attaching the header to the hollow metal door frame, ensure there are 5 attaching screws spaced equally apart. They should be #12 sheet metal type screws.

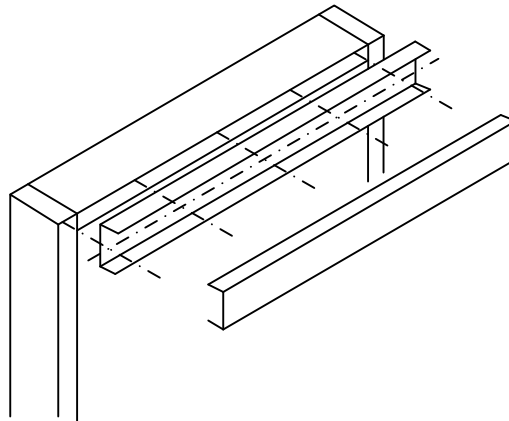

- Fire rated power operated doors must close and latch during a fire alarm condition. Ensure proper procedures have been followed to allow a main power disconnect during a fire alarm condition. Always check to ensure compliance to local building codes.
  - Upon job completion, always perform a functional test to ensure that the door(s) close and latch following a power loss.
- Other hardware may be required to complete the installation. For example, for pairs of doors, if an Astragal is installed, a mechanical door coordinator may be required to ensure a proper coordinated closing during a power loss.
- Only fire rated hardware shall be used on a fire rated door & frame assembly.



## Dip Switch Settings

### SW2 Dipswitch Settings

	Description	ON	OFF
1	Closed Door Force	Additional force applied while door is in closed position. Be sure to maintain ANSI low energy compliance (cannot exceed 30lbf to start door moving).	Disabled (Default)
2	Push / Pull Arm	Slide Arm Application Operator stroke at 90 degrees or less. Visible change in performance may not always be noticeable.	Push Arm Application. Operator stroke 90 degrees or greater. (Default)
3	Night Function (Exit Only)	Allows activation at input 10 when On-Off switch is in OFF position (night function).	Disabled. The On/Off switch, when OFF, requires manual operation of the door. (Default)
4	Push & Go*	Enabled	Disabled (Default)
5	Potentiometer Adjustment	Low Energy 5 seconds to open, 7 seconds hold open, 5 seconds to close. Speed & time potentiometers are disabled. Settings are fixed.	Control can be adjusted for low energy operation via potentiometers. (Default)
6	Lockout Function	Overhead presence sensor input (17) is inhibited during closing cycle unless input (17) is triggered. Connect COM and input (14) to NC output of lockout safety beam.	Disabled. Overhead presence sensor input (17) is inhibited during closing cycle. Otherwise, if commanded, it keeps an open door open and a closed door closed. A command at input 14 will stall the door. (Default)
7	Inhibit at 30 Degrees Before Door Fully Open	Input is disabled at 30 degrees prior to full open door position. Eliminates need for external inhibiting switch.	Stall function remains uninhibited for full door stroke. (Default)
8	Power Close	Additional closing force applied for final 10 degrees of closing.	Disabled (Default)
9	Assisted Manual Closing *	Enabled assisted closing following a manual opening.	Disabled assisted closing following a manual opening. (Default)
10	<b>Factory Use Only</b>		

\* Hager requires the use of a door-mounted safety device when dip switch 4 & 9 are on-enabled.

## J4, J5, and J6 Terminal Inputs

	Terminal	Function	Description
<b>Terminal Strip J5</b>	1	Electric Lock Relay	Common
	2	Electric Lock Relay	N.O. Dry contact – Contact closes upon activation. May be used for fail-secure locks by routing 1 leg of power through the relay. Relay is triggered by activation inputs 10, 11, or 16. Relay remains energized until door is fully closed again.
	3	Electric Lock Relay	N.C. Dry Contact - Contact opens upon activation. May be used for fail-safe locks by routing 1 leg of power through the relay. Relay is triggered by activation inputs 10, 11, or 16. Relay remains energized until door is fully closed again.
	4	Door Status - Closed	N.O. Contact is closed when door is closed. The contact opens as soon as the door opens.
	5	Door Status - Com	Common contact for door status
	6	Door Status - Open	N.C. – Contact is closed when door is open. The contact opens as soon as the door starts to close. This input can be used for motor connection at lockout relay when power is looped through, thus switching power on when door is open.
<b>Terminal Strip J4</b>	7	GND	Common Ground
	8	GND	Common Ground
	9	(+) 24VDC	1 A. Max Current
	10	Internal Activation	Requires N.O. Contact between input 10 & GND. Remains capable to activate when dip switch 3 is ON AND On-Off switch is OFF.
	11	External Activation	Requires N.O. Contact between input 11 & GND.
	12	Emergency Closing	Requires N.C. contact between 12 & GND. Upon open contact, door closes and overrides all other inputs. Remains jumpered if input is not used.
	13	Secondary Activation	Requires N.C. contact between 13 & GND. Disabled in full closed position.
	14	"Stall" Safety	Requires N.C. contact between 14 & GND. Upon open contact, (Dip 6 OFF) during opening, door stops, then resumes at reduced speed when input is released.
	15	KEY	KEY INPUT
	16	Alarm Input	N.O. contact, when closed causes door closing. All inputs inhibited during closed contact (not available on all software versions)
<b>Terminal Strip J6</b>	17	Overhead Presence Sensor Input	Requires N.O. contact between 14 & +24 VDC (input 9). When input is closed it causes an open door to stay open and a closed door to stay closed. Works in conjunction with dip switch #6.
	18	GND	Common Ground
	19	GND	Common Ground
	20	Aux Relay	Auxiliary Relay NOTE: Relay is triggered by input 14
	21	Aux Relay	Auxiliary Relay N.O.
	22	Aux Relay	Auxiliary Relay N.C.
	23	Alarm Output - Com	Common
24	Alarm Output	N.O. output is closed upon closed contact from fire alarm. LED 2 also illuminates.	
25	(+) 24VDC	1 A. Max Current	
26	GND	Common Ground	

## Wiring Diagrams

### 1. Wireless push plates with electric strike.

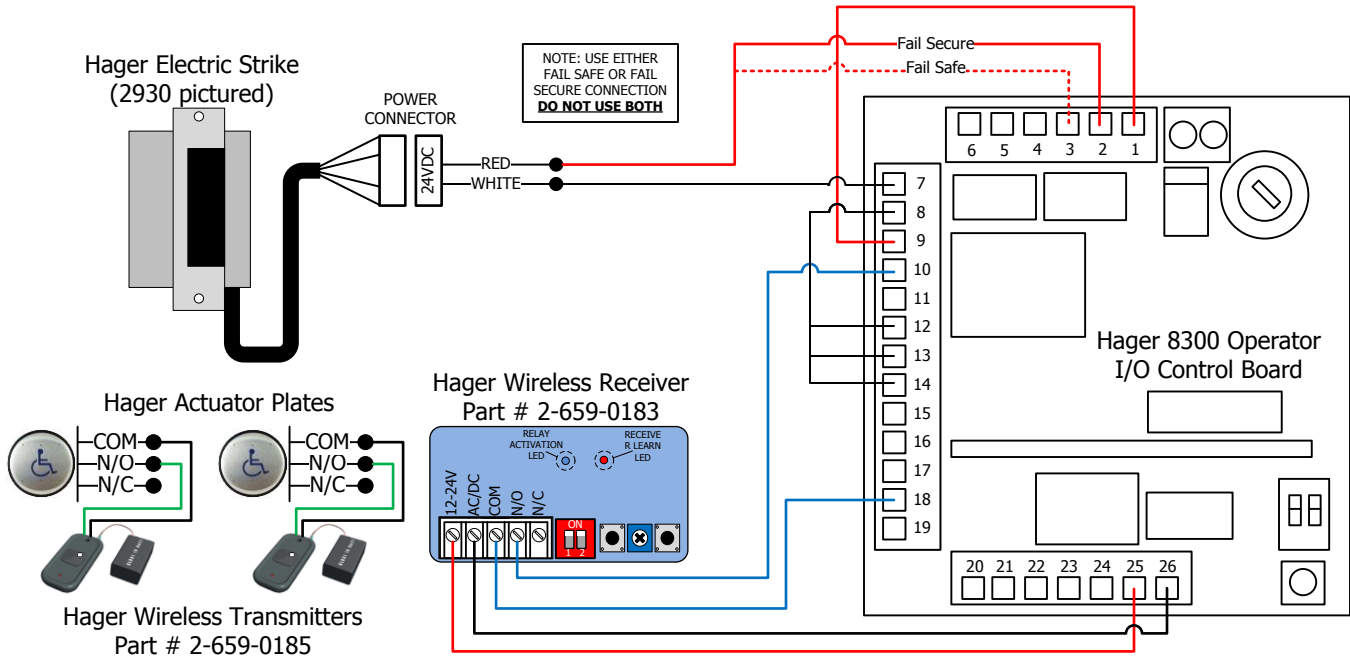

### 2. Hardwired actuators with Hager MLR exit device and day/night mode.

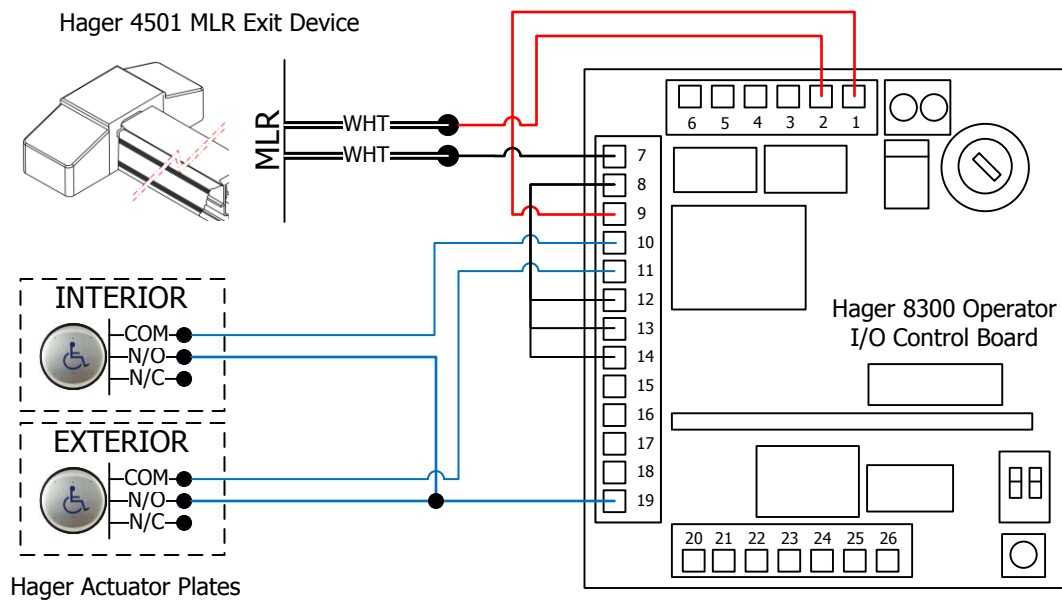

## Programming Device & Troubleshooting

Please note, some functions of the Hager 8300 operator require the use of an optional hand-held programming device.

The following functions require use of this device for programming:

- Logic Assignment For Inputs
- Logic Assignment For Outputs
- Opening & Closing Acceleration
- Opening & Closing Deceleration
- Opening & Closing Strength (obstruction force)
- Opening & Closing Strength Duration (time duration for obstruction force)
- Night-Time Hold Open Time
- Delay On Activation (up to 4 seconds)
- Electric Lock Interfacing
- Master/Slave Configuration
- Cycle Count – Maintenance Reset
- 7-Day Programmable Timer (With Daylight Savings Time)
- Troubleshooting & Data Codes

### Troubleshooting

Door will not open	<ul style="list-style-type: none"> <li>· Check On-Off switch for proper position</li> <li>· Check LED status for LD 5, 6, and 7. If any of these LED's are OFF, the door will not open. They require a normally closed circuit.</li> <li>· Launch a new setup – see page 26</li> <li>· Check status of emergency input 12</li> <li>· Door has traveled close past the 0 degree position</li> </ul>
Door will not close	<ul style="list-style-type: none"> <li>· Check status of LEDs" LD2, 3, 4, 8 on the I/O board.</li> <li>· If any of the LED's are ON, check the associated input</li> </ul>
Door will not reach its full open or closed position	<ul style="list-style-type: none"> <li>· Check the mechanical stops on the operator for proper adjustment</li> </ul>
Slow flashing red LED (LD2) at the Adjustment Control Board	<ul style="list-style-type: none"> <li>· Indicates a possible fault in the control.               <ul style="list-style-type: none"> <li>o Check LED status for the other inputs. This will identify if any inputs are currently active.</li> </ul> </li> <li>· Indicates a potential faulty setup.               <ul style="list-style-type: none"> <li>o Loose or incorrect motor connection</li> <li>o Possible loose chain tensioner - refer to Appendix for chain tensioner adjustment procedures.</li> <li>o Launch a new setup. If problem repeats and there are no other discrepancies noted, replace the operator/control sub-assembly.</li> </ul> </li> </ul>
Door closes too fast at last 5 to 10 degrees of closing	<ul style="list-style-type: none"> <li>· Ensure dip switch 8 is OFF.</li> <li>· Ensure there is no binding of the door as it is closing through the last few degrees of closing. If binding exists (from a tight bottom sweep, for example), correct the condition and then re-launch a new setup.</li> </ul>

**Please direct all technical questions or concerns regarding these installation instructions or this product to [techconnect@hagerco.com](mailto:techconnect@hagerco.com) or call 800-325-9995**