

**MAGNETIC SHEAR LOCK 2965
INSTALLATION INSTRUCTIONS**

REFER TO THE PROPER TEMPLATE ACCORDING TO THE TYPE OF DOOR AND FRAME APPLICATION.

READ THESE INSTRUCTIONS AND STUDY THE TEMPLATE THOROUGHLY BEFORE BEGINNING THE INSTALLATION.

IMPORTANT NOTES:

Although electromagnetic shear locks provide the utmost in aesthetics for fail-safe applications, they are less forgiving than electric bolt locks and direct pull magnetic locks where alignment problems exist. Therefore, great care must be taken during preparation and installation of the frame, door hardware and the shear Magnetic Lock to attain proper alignment and ensure positive lock operation.

Unbalanced air conditioning (stack pressure) can hinder door alignment and must be corrected to help ensure positive locking.

2965 MAGNETIC LOCKS REQUIRE A REGULATED 12 OR 24VDC AT THE LOCK

Use only the highest quality door closer.

POSITIVE CENTERING DOOR CLOSERS ONLY should be used on double acting doors to help attain consistent dead center alignment.

Door latching problems must be corrected prior to installation.

INSTALLATION:

1. Make sure the clearance between the door top rail and frame header is 1/8". Make adjustments to the door as required.

2. Adjust single acting door and door closer to ensure the door settles immediately and is fully closed and at rest against the stop allowing for mutes, smoke seals or weather stripping where applicable.

Adjust double acting door and POSITIVE CENTERING DOOR CLOSER to ensure the door settles immediately and is fully closed and at rest in the dead center of the frame.

3. Locate the vertical centerline of the Magnetic Lock and armature as close as possible to the leading door edge.

CAUTION: Wood door applications require the armature back box to be located an ample distance from the door edge vertical grains, to avoid splitting from wood screws.

4. Determine the horizontal centerline of the door top rail thickness. The armature centerline will be the same. Mark the door per the template.

5. Before determining the frame header centerline, single acting doors must be fully closed and at rest against the stop allowing for mutes, smoke seals or weather stripping where applicable. Double acting doors must be fully closed and at rest in the dead center of the frame.

6. Mark the frame header per the template.

7. Prepare the door and frame per the template.

8. The 2965 Magnetic Lock may be wire to one of two different electrical configurations. An Auto Relock time delay (standard with the 2965) is recommended for all installations to delay relocking 1 to 6 seconds after initial door closure. This will help ensure the door is fully closed and at rest to obtain alignment before the Magnetic Lock is energized. Consult Figure 7 according to material supplied. With the power off make all wire connections to a properly fused power source.

9. Install the Magnetic Lock and armature with the auto relock switch assembly towards the leading edge of the door.
10. For proper operation, the armature must be adjusted upward as close as possible and parallel to the Magnetic Lock without interfering with opening and closing of the door. Proper operation cannot be expected with more than 1/8" clearance between the armature and the MagLock. Use the hex key provided to adjust the armature vertical adjustment screw (the allen head screws centered at both ends of the armature assembly). Turn counter clockwise to raise the armature.
11. With the door closed, turn the lock power on. Check the lateral alignment. The armature shear stops should be centered between each pair of magnet shear stops.
12. If the clearance between the shear stops is sufficient, open and close the door a few times to ensure the Magnetic Lock will lock and unlock positively.
13. Adjust the auto relock switch magnet to avoid early activation and help ensure positive locking on door closure. Adjust inward to delay Magnetic Lock activation. **Do not** adjust higher than the armature rest position.
14. If the shear stops are too close or binding, double check the templating and door alignment, and make corrections as required.
15. If positive locking cannot be attained due to misalignment after the previous adjustments, the armature shear stops can be reversed with the wide clearance shear stops.

CAUTION: The use of armature offset shear stops may correct misalignment but should not be used when proper door latching is inhibited.

16. Repeat steps 10 through 14 as necessary following shear stop replacement.
17. Cycle the door and Magnetic Lock several times after the completion of installation.

MODEL #	LOCK DIMENSION			HOLDING FORCE	POWER CONSUPTION		MODEL #	ARMATURE DIMENSION		
	L	W	D		12VDC	24VDC		L	W	D
2965	10-7/116"	1-1/2"	1-5/8"	2700	800mA	400mA	ITC	11"	1-1/2"	7/8"

FIGURE 1

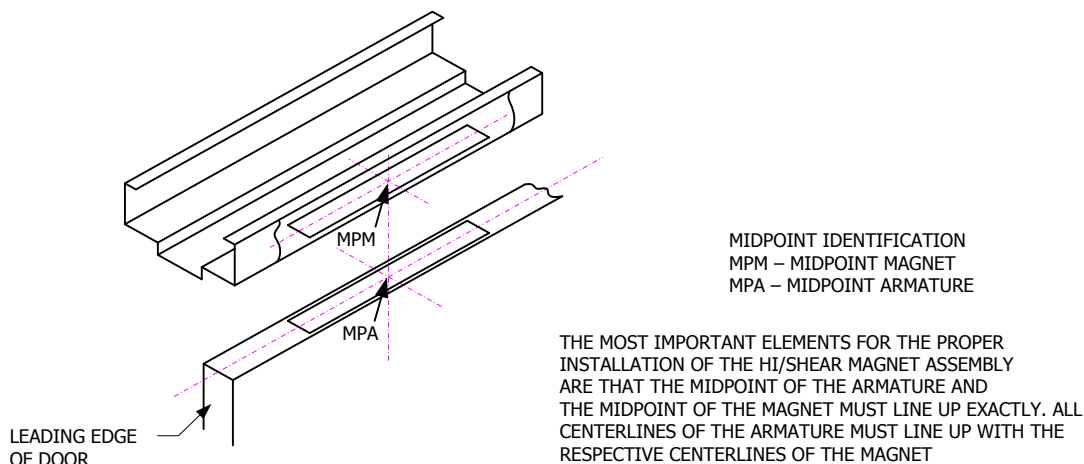

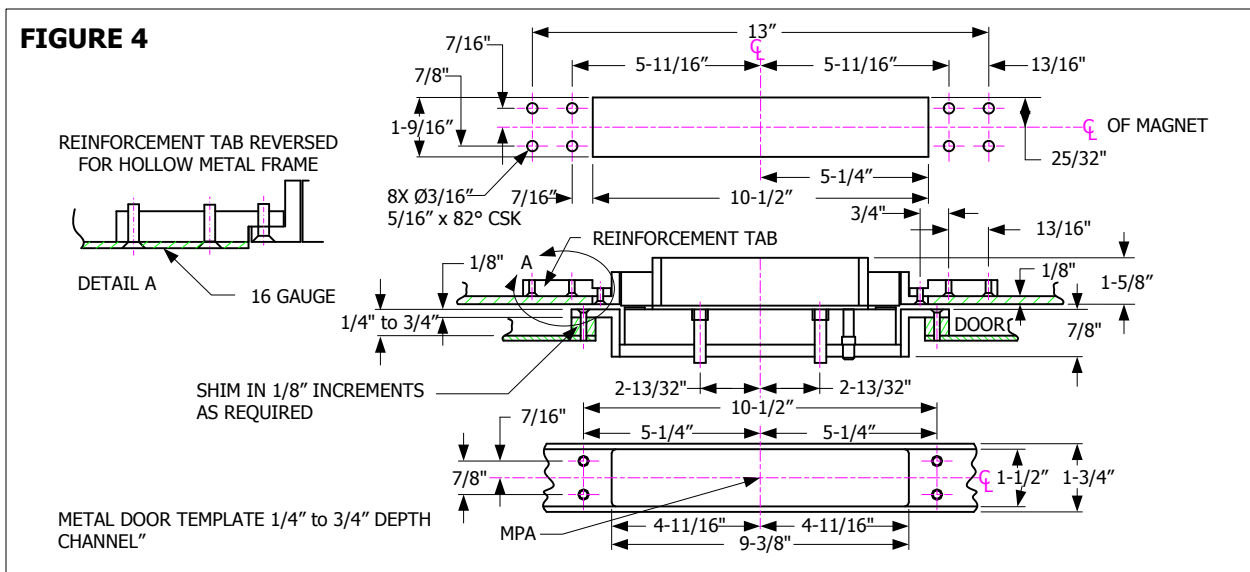
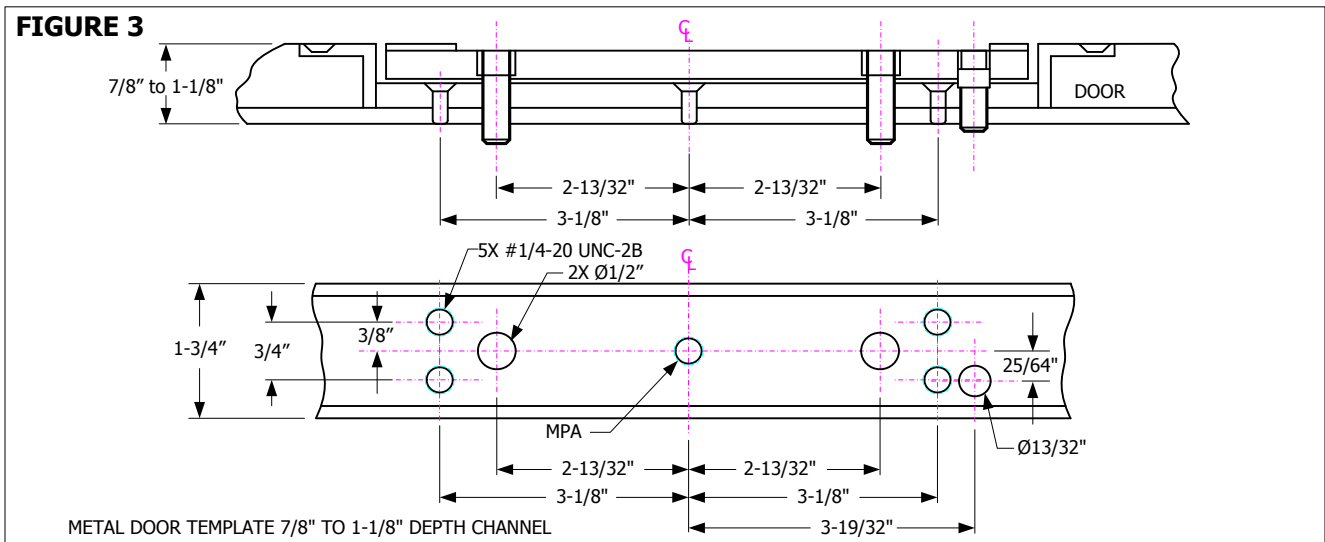
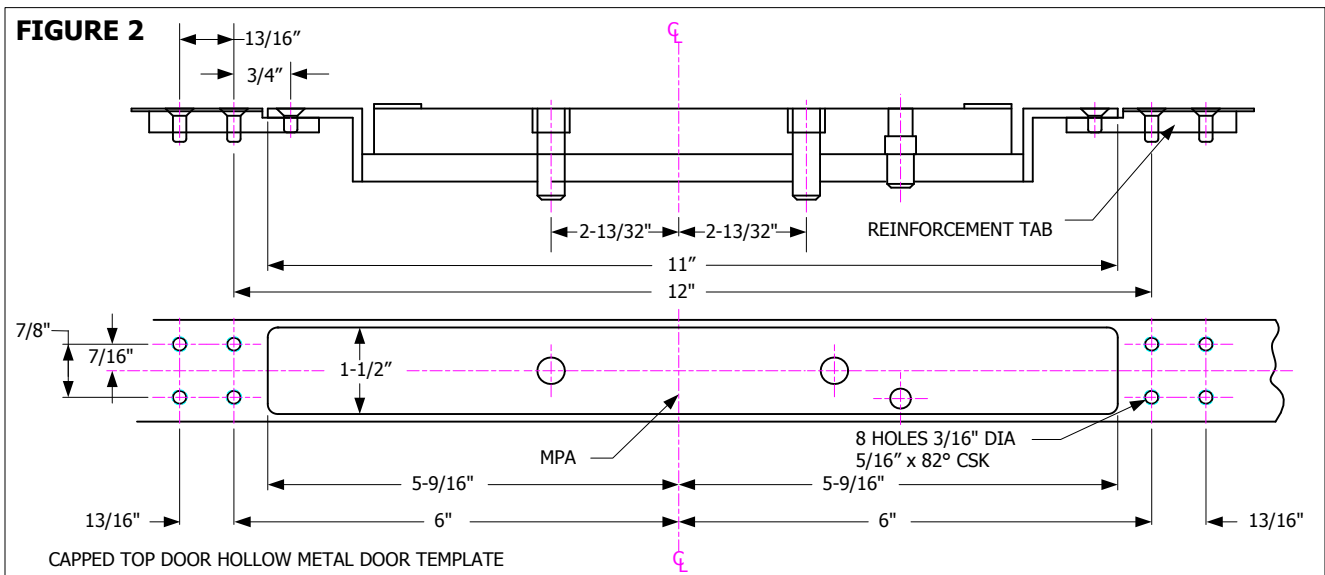

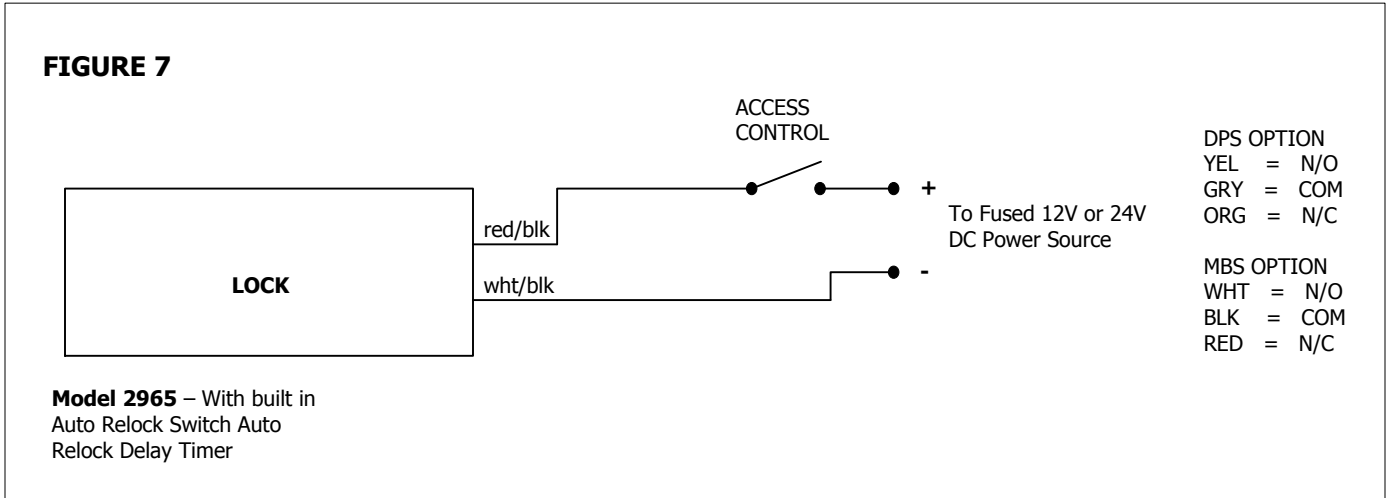
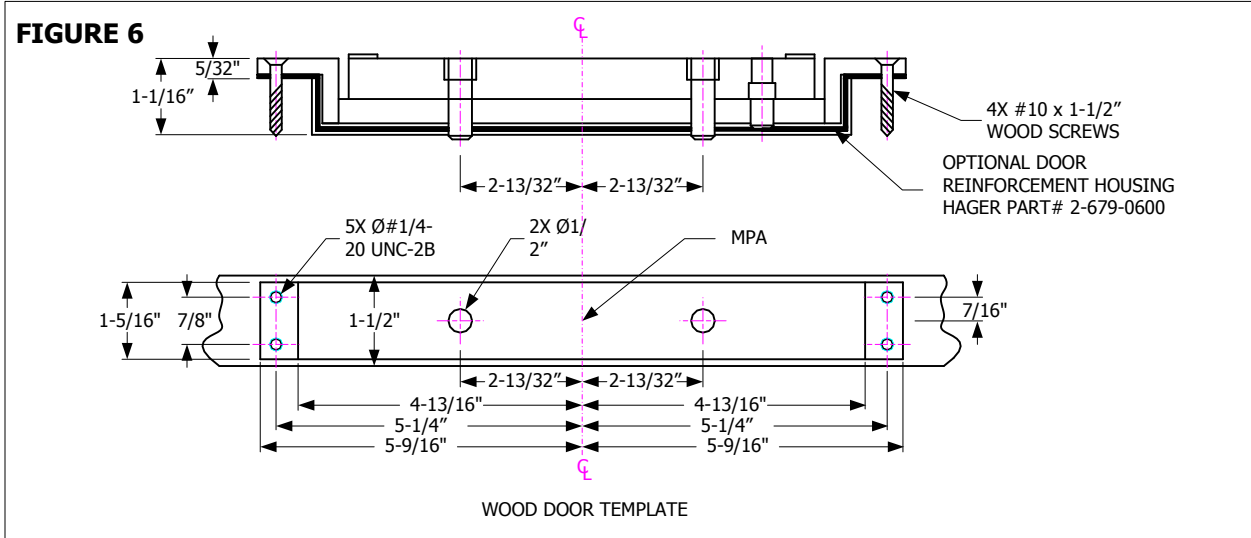
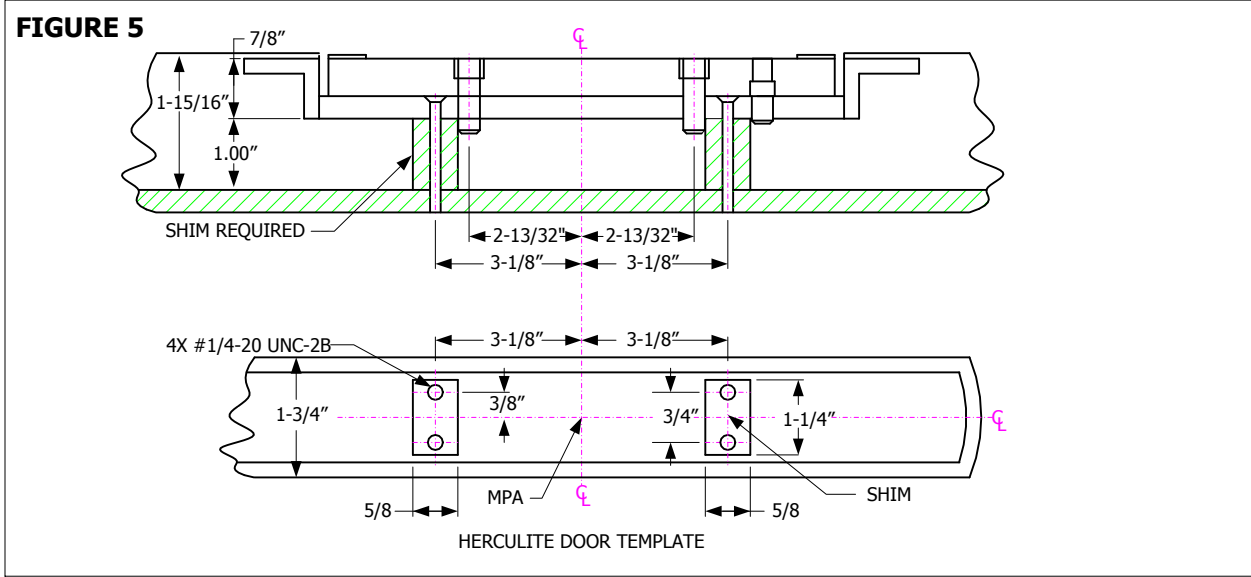

Model 2965 – With built in
Auto Relock Switch Auto
Relock Delay Timer

FIGURE 8

Please note the drawing in Fig. 1, shows two different alignments off center of the shear tab.

For normal single acting door alignment see Fig. 2.

For double acting doors see Fig. 6.

For slightly warped single acting doors see Fig. 4.

This also works well for quick release, when switch bars are used.

The offset shear tab cannot be used on shear locks with bond sensors. Fig 5 & 7.

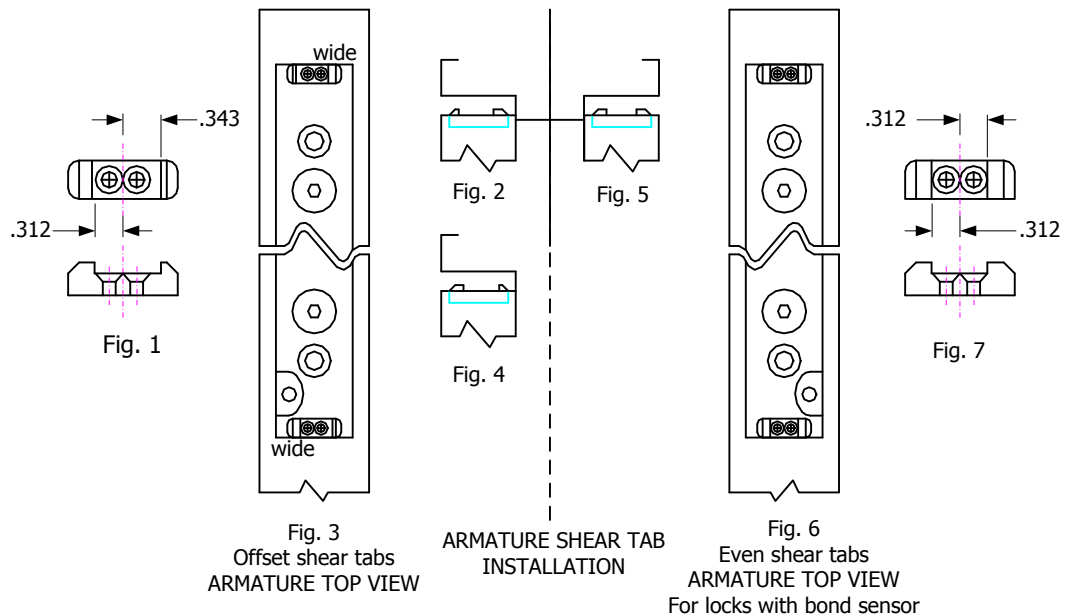

MAINTENANCE INSTRUCTIONS

The electromagnet and the armature should be handled carefully. Any damage to the surface such as paint, burrs, dirt and rust may hinder bonding of the surface and reduce holding power.

IF THE SURFACE PLATING BECOMES DAMAGED

1. Do not touch lock face with your hands.
2. Use a soft clean dry cloth or abrasive cloth (i.e., Scotch-Brite by 3M) to clean the lock face. Do not use sand paper.
3. A rust inhibitor, such as M1 manufactured by Starret, or LPS3 manufactured by LPS Laboratories (available in most hardware stores) can then be applied to the lock face.
4. Apply a coat of rust inhibitor to the armature face also.