

PARTS

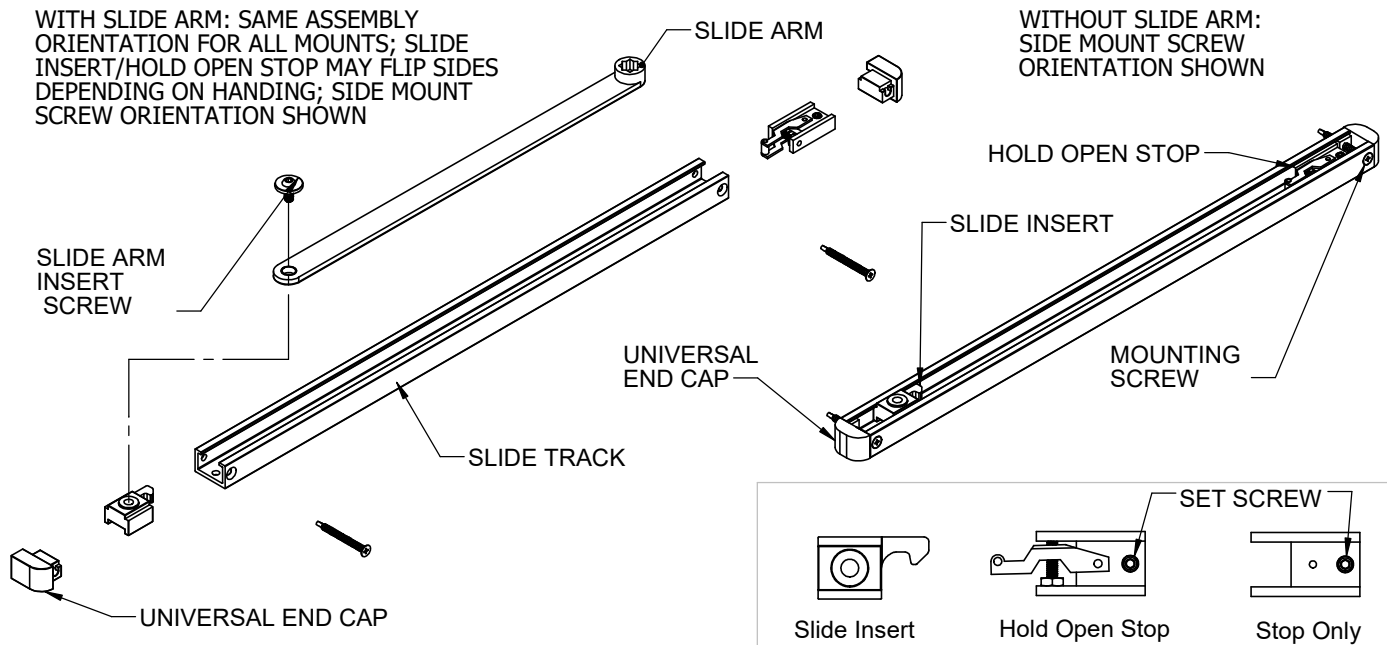

PULL SIDE APPLICATION (RIGHT HAND SHOWN) 120° DOOR PREP

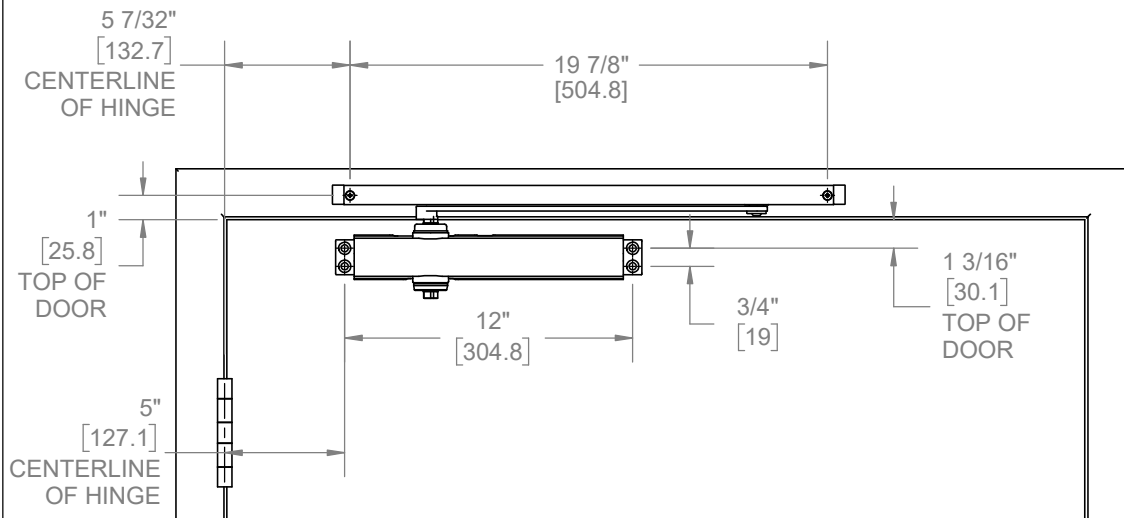

NOTE: IF USER WISHES TO HAVE A LESSER SWING ANGLE, SIMPLY MOVE HOLD OPEN STOP OR STOP ONLY AWAY FROM THE PIVOT HINGE IN INCREMENTS OF 1/2" UNTIL DESIRED ANGLE IS ACHIEVED.

Installation Sequence:

1. Use door prep above to locate holes on door and frame. Drill 1/8" pilot holes for the self tapping screws.
2. Fasten closer body to door with power adjustment port away from hinge.
3. Position slide track to frame face orientated with countersink visible open side facing down and with hold open stop end toward hinge edge of door. Slide end caps on, insert screw through end caps and fasten to the frame.
4. Place slide arm on pinion shaft of closer so arm is positioned at a 45 degree angle out from door face.
5. Secure arm with arm washer and arm screw.
6. To properly preload closer, push arm towards door and secure other end of slide arm to track by screwing it to the slide insert. Open door to required opening angle. Then slide stop only/hold open stop up against slide insert and tighten down the stop only/hold open stop via set screw.
7. Determine door width, adjust spring power of closer by referencing closer adjustments on page 4.

TOP JAMB (PULL SIDE) MOUNTING APPLICATION (RIGHT HAND SHOWN) 120 ° DOOR PREP

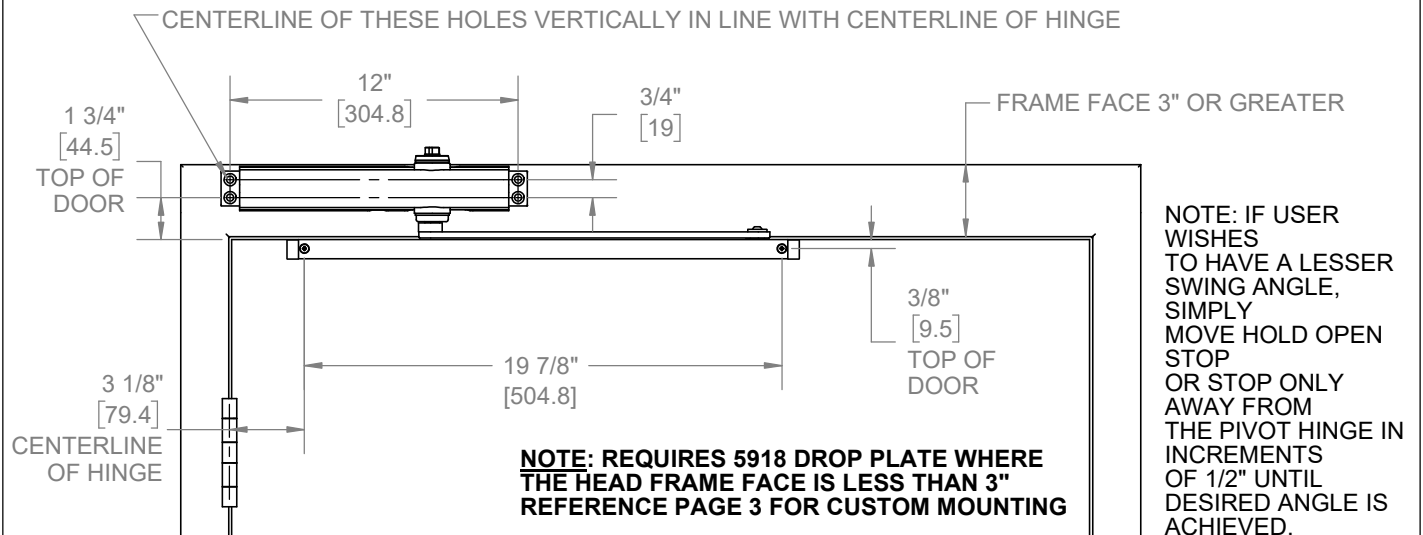

Installation Sequence:

1. Use door prep above to locate holes on door and frame. Drill 1/8" pilot holes for the self tapping screws.
2. Fasten closer body to door with power adjustment port towards hinge.
3. Position slide track to frame face orientated with countersink visible open side facing down and with hold open stop end toward hinge edge of door. Slide end caps on, insert screw through end caps and fasten to the frame.
4. Place slide arm on pinion shaft of closer so arm is positioned at a 45 degree angle out from door face.
5. Secure arm with arm washer and arm screw.
6. To properly preload closer, push arm towards door and secure other end of slide arm to track by screwing it to the slide insert. Open door to required opening angle. Then slide stop only/hold open stop up against slide insert and tighten down the stop only/hold open stop via set screw.
7. Determine door width, adjust spring power of closer by referencing closer adjustments on page 4.

TOP JAMB (PULL SIDE) MOUNT (RIGHT HAND SHOWN) 120° CUSTOM DOOR PREP WITH 5918 PLATE

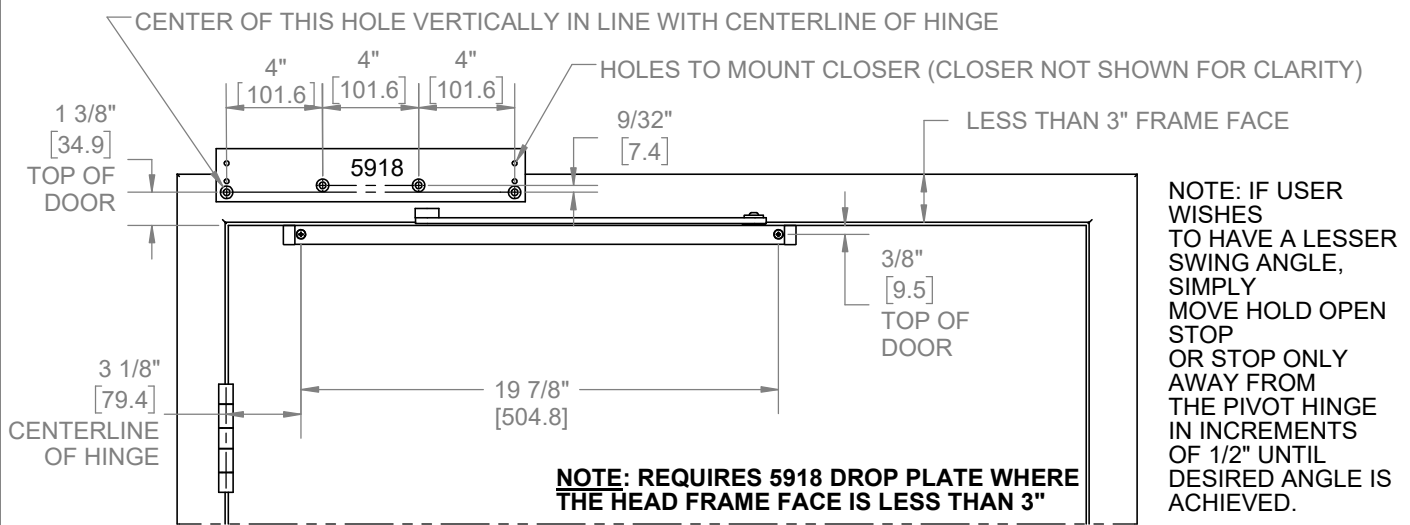

Installation Sequence:

1. Use door prep above to locate holes on door and frame. Drill 1/8" pilot holes for the self tapping screws.
2. Fasten closer body to 5918 plate with power adjustment port towards hinge.
3. Position slide track to frame face orientated with countersink visible open side facing down and with hold open stop end toward hinge edge of door. Slide end caps on, insert screw through end caps and fasten to the frame.
4. Place slide arm on pinion shaft of closer so arm is positioned at a 45 degree angle out from door face.
5. Secure arm with arm washer and arm screw.
6. To properly preload closer, push arm towards door and secure other end of slide arm to track by screwing it to the slide insert. Open door to required opening angle. Then slide stop only/hold open stop up against slide insert and tighten down the stop only/hold open stop via set screw.
7. Determine door width, adjust spring power of closer by referencing closer adjustments on page 4.

POCKET DOOR APPLICATION 90° OPEN DOOR INTO POCKET

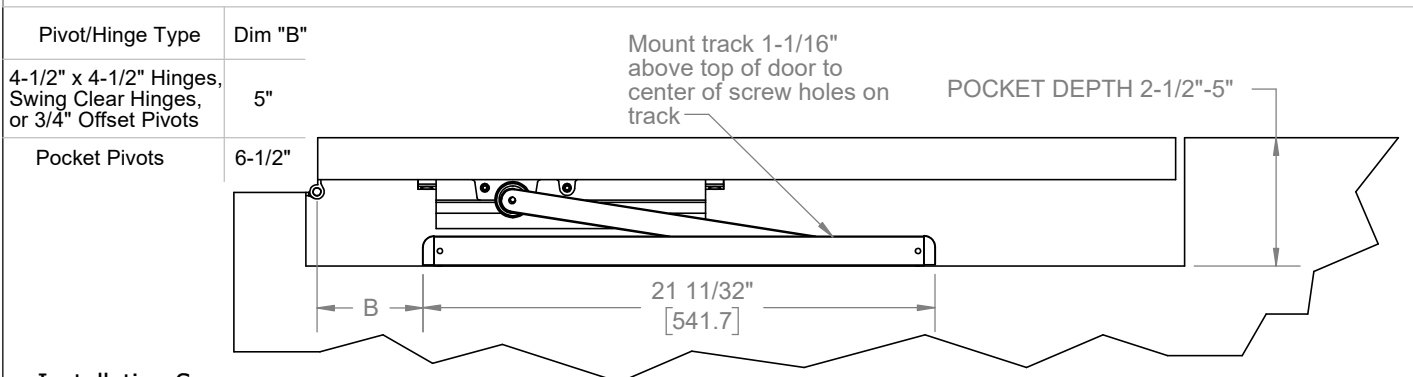

Installation Sequence:

1. Use template above to locate mounting holes on pocket wall and mount closer according to pull side application template. Drill 1/8" pilot holes for the self tapping screws.
2. Determine door width, adjust spring power of closer by referencing closer adjustments on page 4.
3. Fasten closer body to door with power adjustment port away from hinge.
4. Fasten slide track to pocket wall face with open side facing down and with hold open stop end away from hinge edge of door. Slide end caps on, orientated with countersink visible. Screw will go through end caps as it fastens to the frame.
5. Connect slide arm to track by screwing it to the slide insert. **DOOR MUST REMAIN IN CLOSED POSITION FOR FOLLOWING ASSEMBLY STEPS.**
6. Swing arm toward closer and rest the hub of the arm on top of the closer pinion. Place a wrench on the bottom pinion of the closer and rotate away from the hinge (approx. 30 degrees). When the cutout of the arm hub and the pinion line up, slide the arm hub down over the pinion and secure tightly with the washer and screw. This pretensions the closer arm.
7. Loosen the stop only/hold open stop and open door to required opening angle. Close the door. Now slide the stop only/hold open stop back towards the hinge about 1/2" and tighten down the stop only/hold open stop via set screw.

5200 DOOR CLOSER ADJUSTMENTS

ADJUSTMENTS (USE 5/32" HEX WRENCH FOR THESE ADJUSTMENTS)

SWEEP SPEED

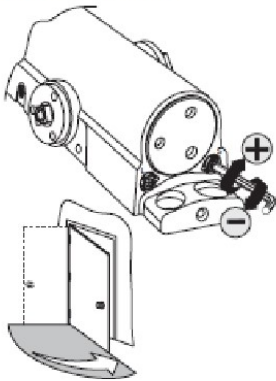

Note: Adjust closing time speed to between 3 and 7 seconds from 90° to 0°. Greater closing times may be required for elderly or handicapped.

LATCH SPEED

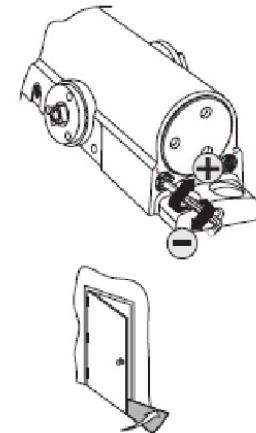

Adjust latch speed so door completely closes and latches.

BACKCHECK

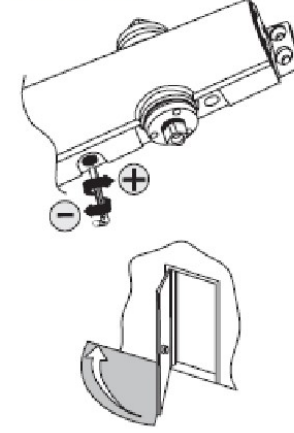

Adjust backcheck accordingly to prevent excessive opening speed.

SPRING POWER ADJUST (Sizing in accordance to BHMA/ANSI 156.4)

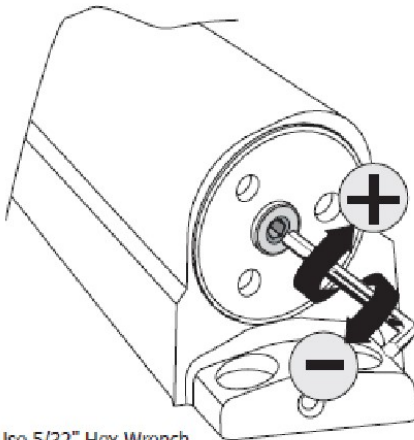

(Use 5/32" Hex Wrench for this adjustment)

TABLE OF SIZES

Closer is shipped set to size 3. To change the closer size, use a hex wrench to rotate the spring power adjust. Follow the chart to make the correct numbers of 360° turns to set the closer size appropriately for the door application.

The number of turns is an approximation and does not account for environmental or door hardware affects.

cw = clockwise
 ccw = counterclockwise

Exterior (and Vestibule) Door Width

Minimum Door Width (24")
 24" - 30" - 36" - 42" - 48"
 (610 mm)(762 mm)(914 mm)(1067 mm)(1219 mm)

Regular Arm & Top Jamb	Size 3 (0)	Size 4 (4cw)	Size 5 (8cw)	Size 6 (12cw)
	Size 3 (4cw)	Size 4 (8cw)	Size 5 (12cw)	
Parallel Arm				

Interior Door Width

Minimum Door Width (24")
 24" - 30" - 34" - 38" - 48" - 54" - 60"
 (610 mm)(762 mm)(865 mm)(965 mm)(1219 mm)(1372 mm)(1524 mm)

Regular Arm & Top Jamb	Size 1 (8ccw)	Size 2 (4ccw)	Size 3 (0)	Size 4 (4cw)	Size 5 (8cw)	Size 6 (12cw)
	Size 1 (4ccw)	Size 2 (0)	Size 3 (4cw)	Size 4 (8cw)	Size 5 (12cw)	
Parallel Arm						