

CAUTION An incorrectly installed or improperly adjusted door closer can cause property damage or personal injury. These installation instructions should be followed to avoid the possibility of misapplication or misadjustment.

CAUTION

- Hollow-metal doors require channel or box-type reinforcement when thru-bolt mount is specified.
- Hold open arms are not permitted on fire doors.
- Sex-bolts may be required for wood or plastic faced fire door mounting.
- Minimum thickness recommended for reinforcements in hollow metal doors and frames: (12GA).
- Dimensions are based on standard doors and frames with 1/8" clearance, 5/8" stops.

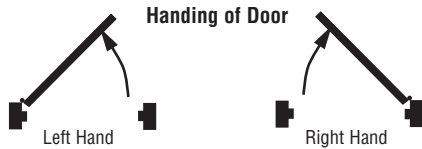

These door closers should NOT be installed on the exposed side (weather side) of exterior doors.

<p>TOOLS REQUIRED</p>	<p>METAL</p>	<p>WOOD</p>	<p>Self Drilling Screws Wood and Metal</p> <p>For wood, drill 3/16" hole</p> <p>Machine Screws</p> <p>#7 Drill, 1/4" - 20 Tap</p>	<p>Sleeve Nut and Bolt</p> <p>Drill 9/32" thru from Closer Side 3/8" Drill other Side</p> <p>Check building and fire codes to see if your application requires the use of sleeve nuts and bolts.</p>
------------------------------	---------------------	--------------------	---	---

5200 CLOSER COMPONENT PARTS

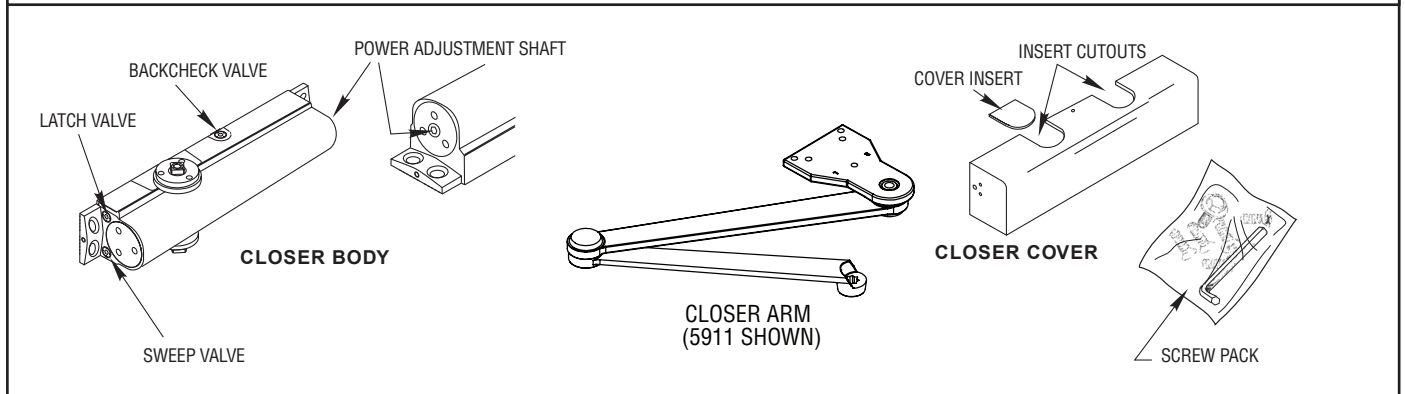

5300 CLOSER COMPONENT PARTS

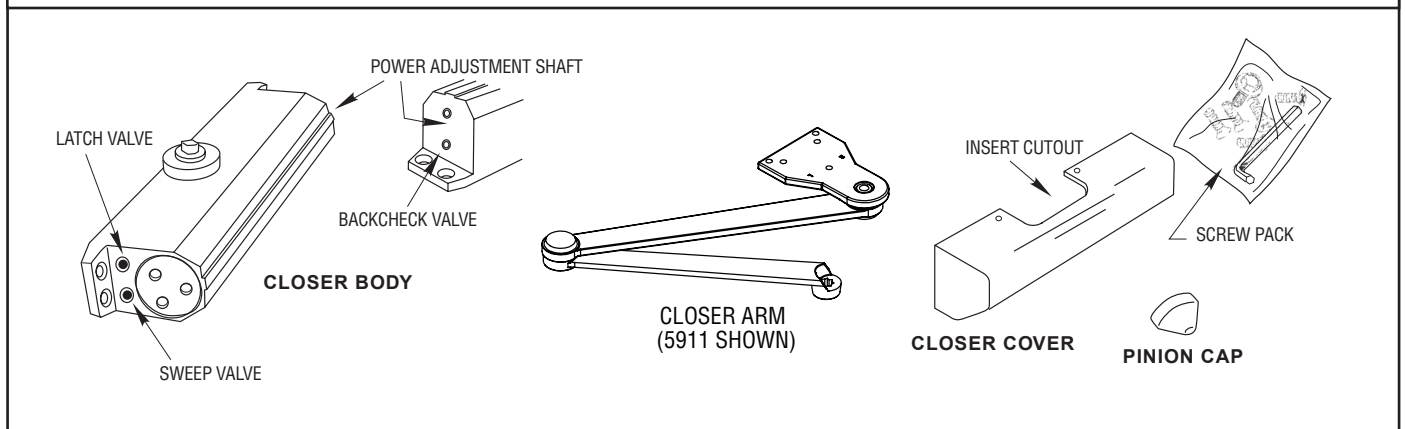

1. MARK AND DRILL HOLES (RIGHT HAND SHOWN)

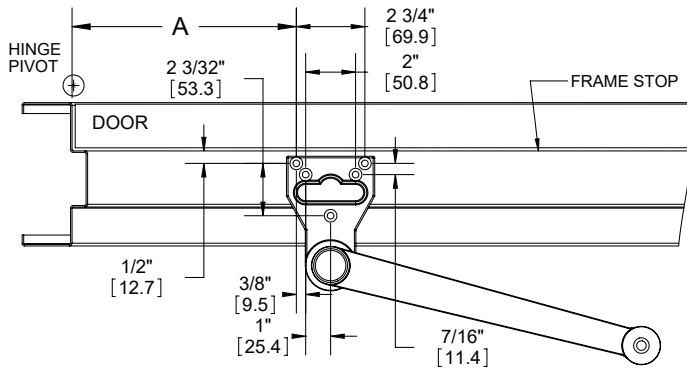

Locate the arm and degree of opening for this installation. Use the chart below to mark/drill/tap (4) 1/4-20 holes for the door. Also, mark/drill/tap (5) 1/4-20 holes in the frame soffit and/or rabbet.

5906 Extra Heavy Duty Hold Open Stop Arm, 5957 Heavy Duty Cushion Stop Arm, 5907 Extra Heavy Duty Stop Arm, & 5956 Extra Heavy Duty Hold Open Cushion Stop Arm:

5200 CLOSER MOUNTING CHART

Dim. "A"	Dim. "B"	Door Opening with Stop	Door Opening w/o Stop
10"	4-1/2"	90°	105°
8-3/4"	3-1/2"	100°	105 - 130°
7-1/2"	2"	110°	130 - 170°

5200 DOOR CLOSER PREP. (RIGHT HAND SHOWN)

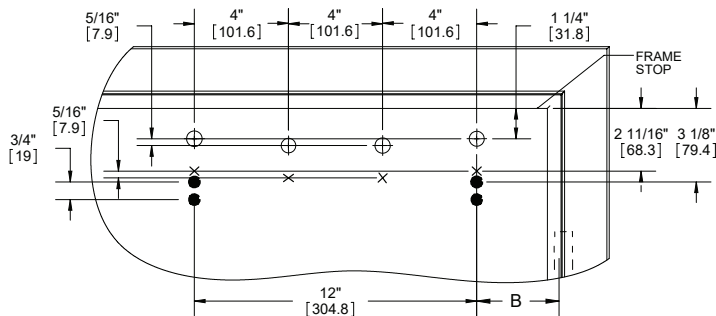

⊕ Prepare these 4 holes for 5922 or 5923 drop plates only. X Prepare these 4 holes for 5918 drop plate only. ● Prepare these 4 holes for standard installation of closer to door without drop plate.

5300 CLOSER MOUNTING CHART

Dim. "A"	Dim. "B"	Dim. "C"	Door Opening with Stop	Door Opening w/o Stop
10"	8-1/8"	9-1/8"	90°	105°
8-1/2"	6-1/2"	7-1/2"	100°	105 - 130°
7-1/2"	5-7/16"	6-7/16"	110°	130 - 170°

5911 Extra Heavy Duty Arm & 5912 Extra Heavy Duty Hold Open Arm:

5200 CLOSER MOUNTING CHART

Dim. "A"	Dim. "B"	Door Opening
8-15/16"	3-7/16"	up to 120°
7-3/16"	1-3/4"	up to 180°

5300 DOOR CLOSER PREP. (RIGHT HAND SHOWN)

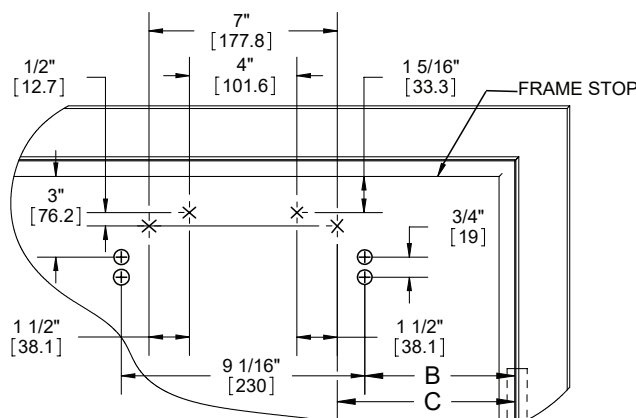

X Prepare these 4 holes for 5915 or 5916 drop plate only. O Prepare these 4 holes for standard installation of closer body to door without drop plate.

5300 CLOSER MOUNTING CHART

Dim. "A"	Dim. "B"	Dim. "C"	Door Opening
8-7/8"	6-7/8"	7-7/8"	up to 120°
7-3/16"	5-1/8"	6-1/8"	up to 180°

*This table was made using 4 1/2" wide hinges. Use of larger hinges or swing clear hinges will yield different results.

**Only use Dim "C" if using a drop plate.

Drop Plate Part #	Minimum Top Rail	Closer
5915 & 5916	3"	5300
5918	4"	5200
5922 & 5923	2-1/2"	5200

Drop plate may be needed in special situations.

2. ARM AND CLOSER BODY INSTALLATION

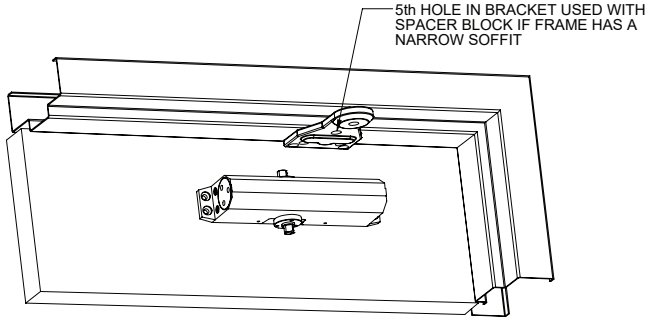

- Screw closer body to the door using (4) 1/4-20 x 1 1/2" screws. The speed regulating valves on the closer must face lock stile of door.
- Screw arm bracket to frame soffit using (5) 1/4-20 x 1 1/2" screws. Do not tighten screws all the way to make mounting the arm to the closer easier.

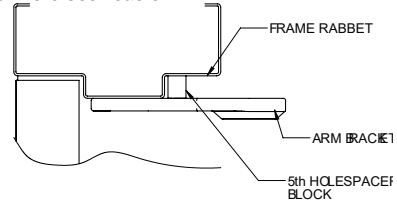

The fifth hole spacer shown above can be used when a narrow soffit prevents normal mounting. Drill/tap a 1/4-20 hole in the frame rabbet. Place the spacer between the bracket and frame and tighten using a 1/4-20 x 2" screw.

OPTIONAL DROP PLATE INSTALLATION

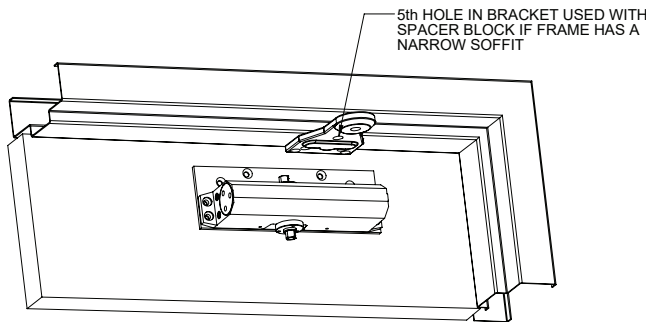

- If using a drop plate, screw the drop plate to the door using 1/4-20 screws. Screw closer to the drop plate using 7/16" long machine screws.

3. MOUNT ARM TO CLOSER

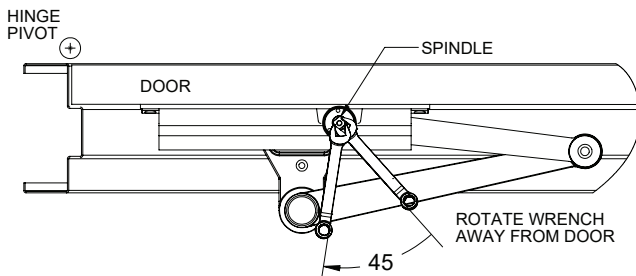

- Use an adjustable wrench to rotate the bottom pinion shaft about 45 degrees in the direction away from the door.
- Place arm on the top pinion shaft so that the "R" or the "L" is in line with the pinion flat as shown in the picture below.
- Attach the arm securely to the closer with the pinion screw. Tighten bracket to the frame if it was left loose during arm installation.

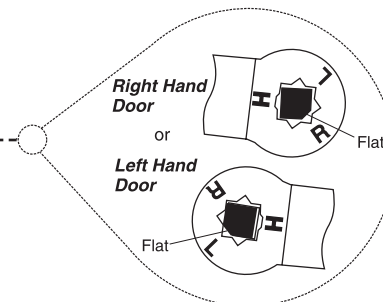
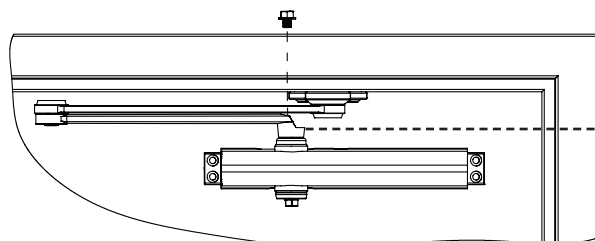

5906 EXTRA HEAVY DUTY HOLD OPEN STOP ARM &
 5956 EXTRA HEAVY DUTY HOLD OPEN CUSHION STOP ARM

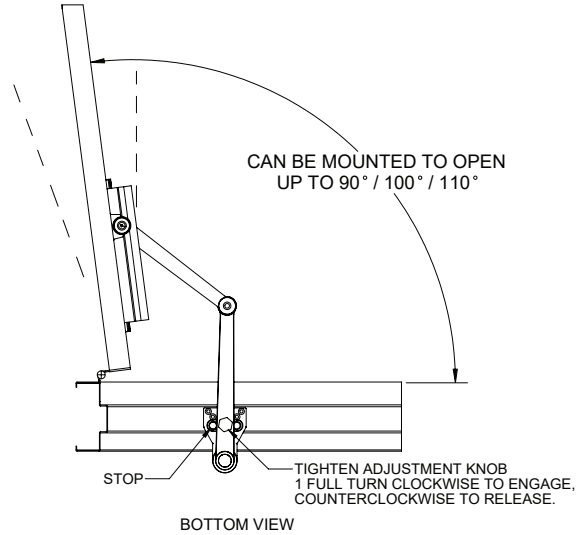
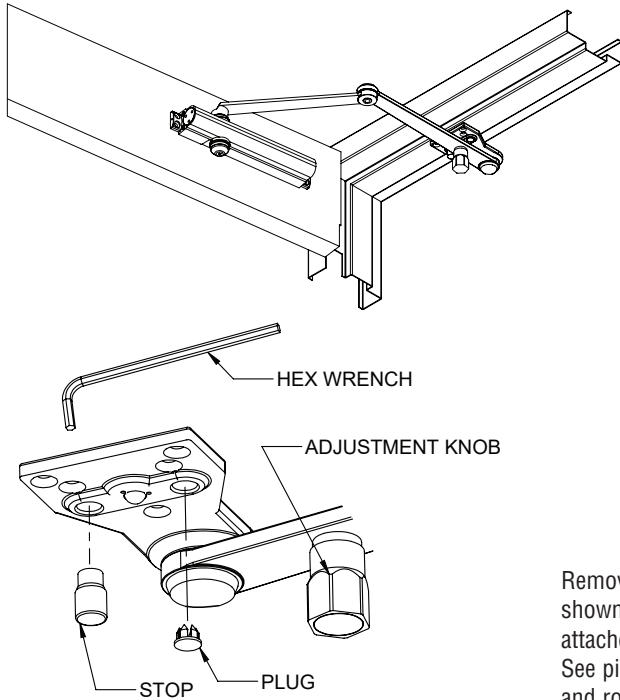

Removable stop can be used for right hand or left hand application (currently shown in right hand application). Stop can only be removed when arm is not attached to the frame. Use a 6mm wrench to unscrew stop and move it. See picture to the left. To engage hold open feature, open door to the stop and rotate adjustment knob clockwise to engage, counterclockwise to release.

5907 EXTRA HEAVY DUTY STOP ARM
 5957 EXTRA HEAVY DUTY CUSHION STOP ARM (CUSHION STOP NOT SHOWN)

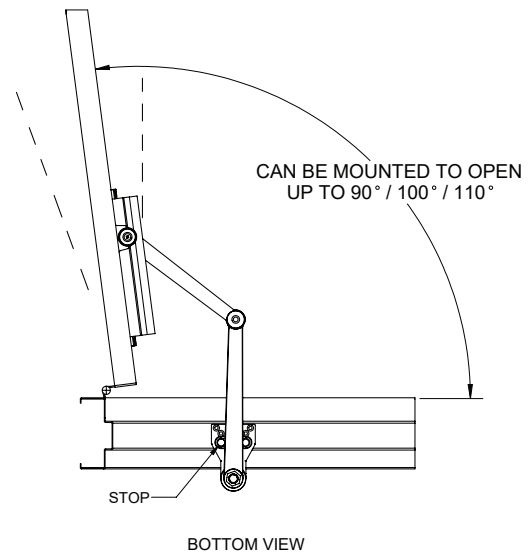
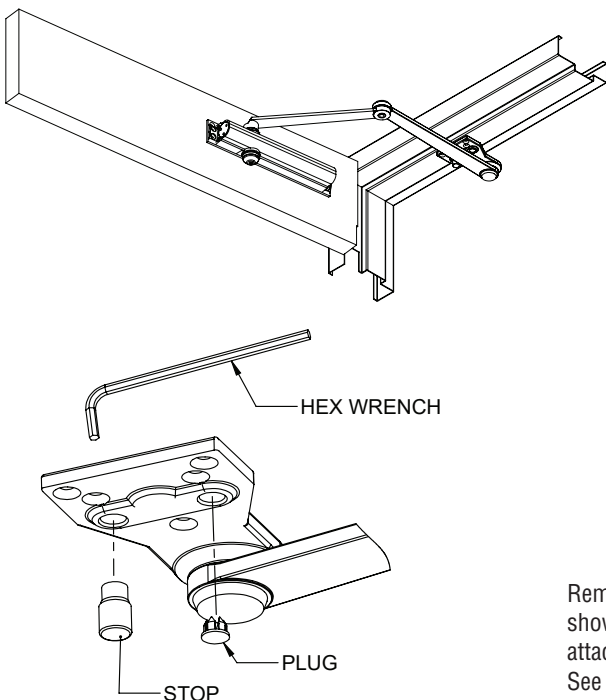

Removable stop can be used for right hand or left hand application (currently shown in right hand application). Stop can only be removed when arm is not attached to the frame. Use a 6mm wrench to unscrew stop and move it. See picture to the left.

5911 EXTRA HEAVY DUTY ARM

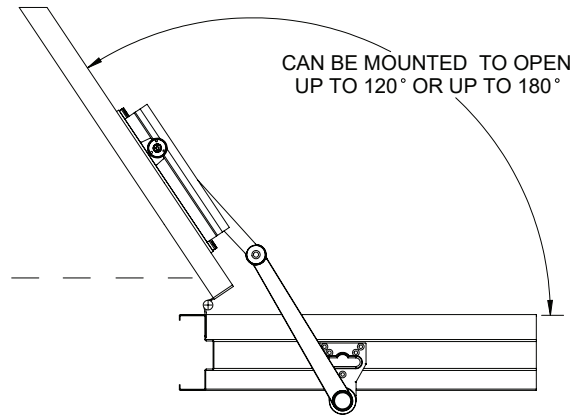
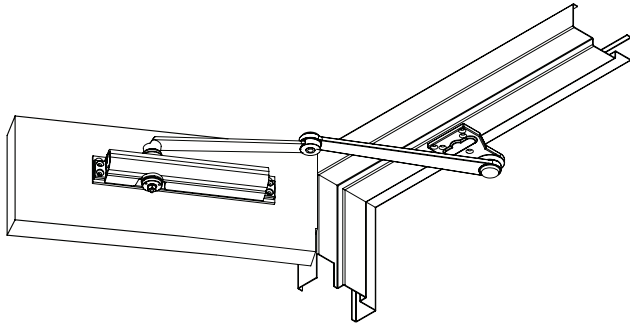

5912 EXTRA EXTRA HEAVY DUTY HOLD OPEN ARM

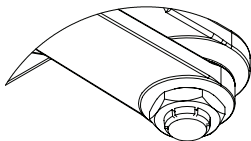
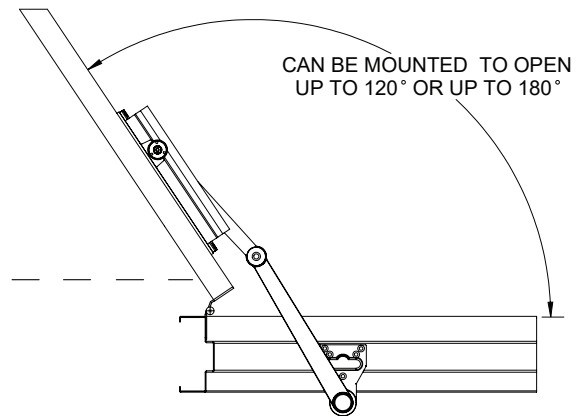
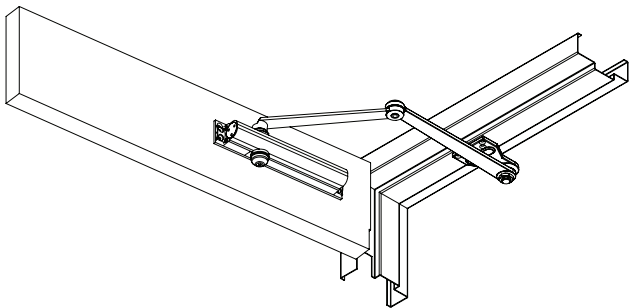

To adjust hold open setting, open the door to about 5 degrees less than the desired position. Use wrench to securely tighten nut on the hold open arm (currently shown in right-handed application).

Install Cover (5200)

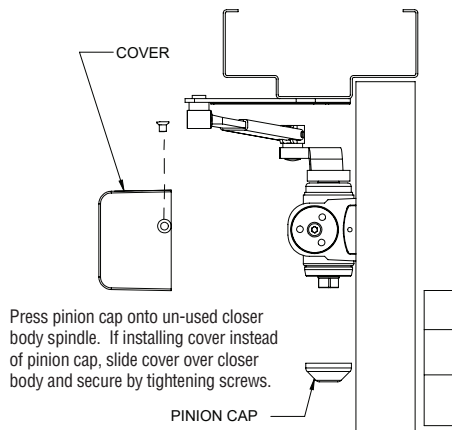

Install Cover/Pinion Cap (5300)

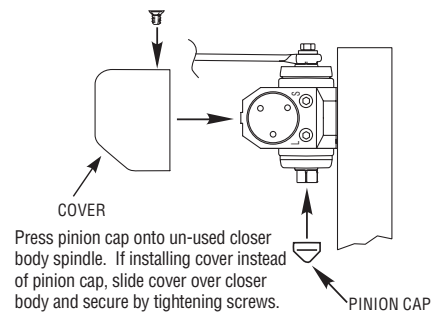

5300 CLOSER ADJUSTMENTS (USE 5/32" HEX WRENCH FOR THESE ADJUSTMENTS)

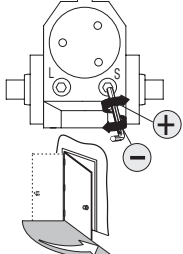
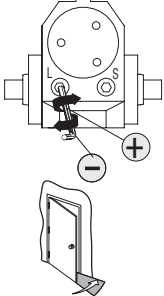
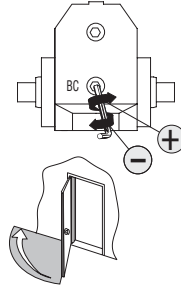
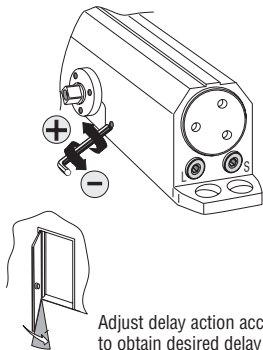
<p style="text-align: center;">SWEEP SPEED</p>  <p>Note: Adjust closing time speed between 3 and 7 seconds from 90° to 0°. Greater closing times may be required for elderly or handicapped.</p>	<p style="text-align: center;">LATCH SPEED</p>  <p>Adjust latch speed so door completely closes and latches.</p>	<p style="text-align: center;">BACKCHECK</p>  <p>Adjust backcheck accordingly to prevent excessive opening speed.</p>	<p style="text-align: center;">OPTIONAL DELAY ACTION</p>  <p>Adjust delay action accordingly to obtain desired delay time.</p>
--	--	--	--

SPRING POWER ADJUST (SIZING IN ACCORDANCE TO BHMA/ANSI 156.4)

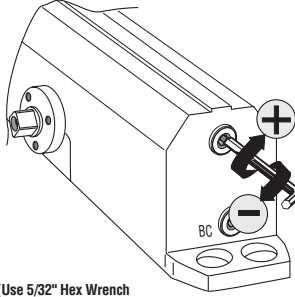

(Use 5/32" Hex Wrench for this adjustment)

TABLE OF SIZES

Closer is shipped set to size 3. To change the closer size, use a hex wrench to rotate the spring power adjust. Follow the chart to make the correct number of 360° turns to set the closer size appropriately for the door application.

The number of turns is an approximation and does not account for environmental or door hardware affects.

Approx. 5 turns to increase / decrease one size.

cw = clockwise
ccw = counterclockwise

Exterior (and Vestibule) Door Width

Minimum Door Width (24")

	24" - 30" (610mm)	30" - 36" (762mm)	36" - 42" (914mm)	42" - 48" (1067mm)
Regular Arm & Top Jamb	Size 3 (0)	Size 4 (5cw)	Size 5 (10cw)	Size 6 (15cw)
Parallel Arm	Size 3 (5cw)	Size 4 (10cw)	Size 5 (15cw)	

Interior Door Width

Minimum Door Width (24")

	24" - 30" (610mm)	30" - 34" (762mm)	34" - 38" (865mm)	38" - 48" (965mm)	48" - 54" (1219mm)	54" - 60" (1372mm)
Regular Arm & Top Jamb	Size 1 (10ccw)	Size 2 (5ccw)	Size 3 (0)	Size 4 (5cw)	Size 5 (10cw)	Size 6 (15cw)
Parallel Arm	Size 1 (5ccw)	Size 2 (0)	Size 3 (5cw)	Size 4 (10cw)	Size 5 (15cw)	

5200 CLOSER ADJUSTMENTS (USE 5/32" HEX WRENCH FOR THESE ADJUSTMENTS)

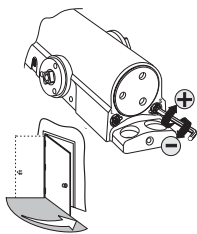
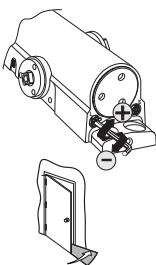
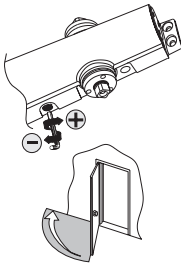
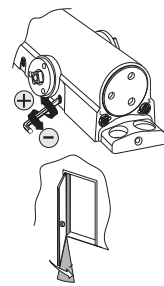
<p style="text-align: center;">SWEEP SPEED</p>  <p>Note: Adjust closing time speed between 3 and 7 seconds from 90° to 0°. Greater closing times may be required for elderly or handicapped.</p>	<p style="text-align: center;">LATCH SPEED</p>  <p>Adjust latch speed so door completely closes and latches.</p>	<p style="text-align: center;">BACKCHECK</p>  <p>Adjust backcheck accordingly to prevent excessive opening speed.</p>	<p style="text-align: center;">OPTIONAL DELAY ACTION</p>  <p>Adjust delay action accordingly to obtain desired delay time.</p>
--	--	--	--

SPRING POWER ADJUST (SIZING IN ACCORDANCE TO BHMA/ANSI 156.4)

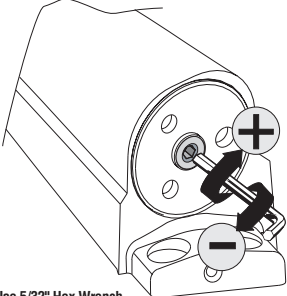

(Use 5/32" Hex Wrench for this adjustment)

TABLE OF SIZES

Closer is shipped set to size 3. To change the closer size, use a hex wrench to rotate the spring power adjust. Follow the chart to make the correct number of 360° turns to set the closer size appropriately for the door application.

The number of turns is an approximation and does not account for environmental or door hardware affects.

Approx. 5 turns to increase / decrease one size.

cw = clockwise
ccw = counterclockwise

Exterior (and Vestibule) Door Width

Minimum Door Width (24")

	24" - 30" (610mm)	30" - 36" (762mm)	36" - 42" (914mm)
Regular Arm & Top Jamb	Size 3 (0)	Size 4 (5cw)	Size 5 (10cw)
Parallel Arm	Size 3 (5cw)	Size 4 (10cw)	

Interior Door Width

Minimum Door Width (24")

	24" - 30" (610mm)	30" - 34" (762mm)	34" - 38" (865mm)	38" - 48" (965mm)	48" - 54" (1219mm)
Regular Arm & Top Jamb	Size 1 (10ccw)	Size 2 (5ccw)	Size 3 (0)	Size 4 (5cw)	Size 5 (10cw)
Parallel Arm	Size 1 (5ccw)	Size 2 (0)	Size 3 (5cw)	Size 4 (10cw)	