

REV.	DESCRIPTION	ECO NO.	DATE
-	INITIAL CHECK IN	TW17002	1/23/2018

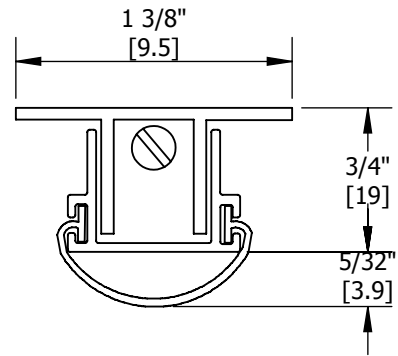

MAX 1/2" DROP



PROPRIETARY & CONFIDENTIAL
 THE INFORMATION CONTAINED
 IN THIS DRAWING IS THE SOLE
 PROPERTY OF HAGER
 COMPANIES. ANY REPRODUCTION
 IN PART OR AS A WHOLE WITHOUT
 THE WRITTEN PERMISSION OF
 HAGER COMPANIES IS PROHIBITED

HAGER RESERVES
 THE RIGHT TO
 MAKE DESIGN
 CHANGES
 WITHOUT NOTICE.
 CALL HAGER
 ENGINEERING AT
 1-800-325-9995
 FOR THE LATEST
 REVISION DATE
 OF TEMPLATE.

	DRAWN	PK	1/23/2018	742S AUTO DOOR BOTTOM	
	ENG. APPR.	-	-		
MATERIAL	Material <not specified>			Q.A.	
FINISH	-			TOLERANCES: FRACTIONAL: ±0.015" ANGULAR: MACH: ± 1° BEND: ± 1° TWO PLACE DECIMAL: ±0.01" THREE PLACE DECIMAL: ±0.004"	
DO NOT SCALE DRAWING				SIZE A	DWG. NO. S-TW00292
				SCALE: 1:1	WEIGHT: 0.06
					REV. - SHEET 1 OF 1