

1

2

3

4

REV	DATE	EDITOR	ECO NO.	CHANGE DESCRIPTION
-	01 Jul 2020	MA		

A
B
C
D

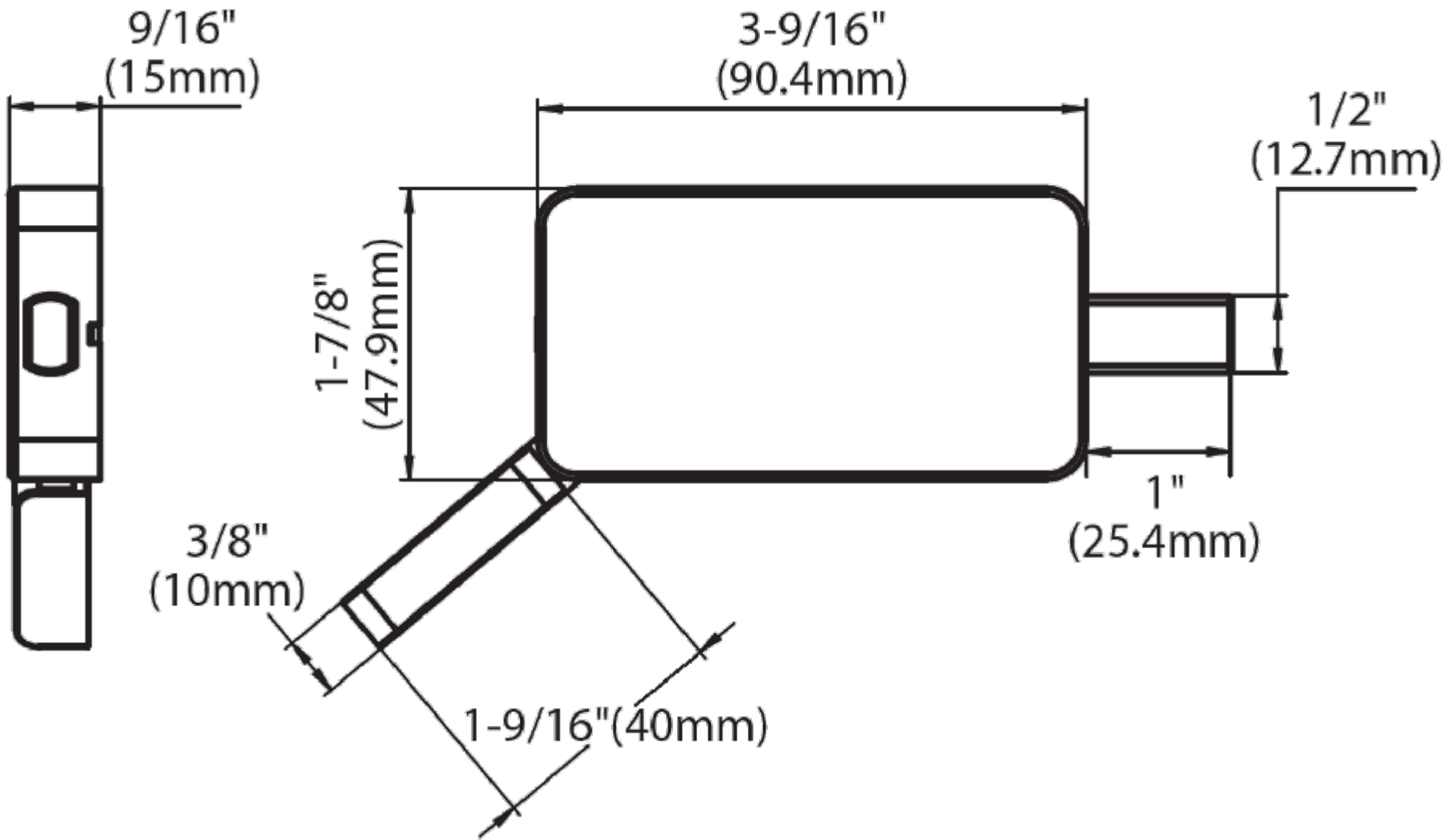

PROPRIETARY & CONFIDENTIAL
 THE INFORMATION CONTAINED IN THIS DRAWING IS THE SOLE PROPERTY OF HAGER COMPANIES. ANY REPRODUCTION IN PART OR AS A WHOLE WITHOUT THE WRITTEN PERMISSION OF HAGER COMPANIES IS PROHIBITED.

HAGER RESERVES THE RIGHT TO MAKE DESIGN CHANGES WITHOUT NOTICE. CALL HAGER ENGINEERING AT 1-800-325-9995 FOR THE LATEST REVISION DATE OF TEMPLATE.

ALL DIMENSIONS REFERENCE UNLESS TOLERANCE SPECIFIED.	DRAWN BY:	MA	7/1/2020	SERIES NO.	PART NO.
	ENG. APPR.:			PART DESCRIPTION:	
	THIRD ANGLE PROJECTION			Sliding Barn Door Surface Jamb Mount Privacy Lock	
	MATERIAL:			DRAWING NO.	REVISION
UNITS: INCH = AUTHORITY [] = MILLIMETER REFERENCE	9459 Stainless Steel			S-SD00393	-
DO NOT SCALE	FINISH: 32D/630 and 19G			SHEET SIZE: A	SCALE: 1:1
WEIGHT: lbs			SHEET 1 OF 1		