

REV.	DESCRIPTION	ECO NO.	DATE
------	-------------	---------	------

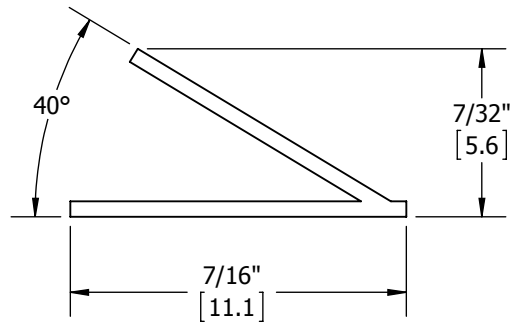

PROPRIETARY & CONFIDENTIAL
 THE INFORMATION CONTAINED
 IN THIS DRAWING IS THE SOLE
 PROPERTY OF HAGER
 COMPANIES. ANY REPRODUCTION
 IN PART OR AS A WHOLE WITHOUT
 THE WRITTEN PERMISSION OF
 HAGER COMPANIES IS PROHIBITED.

HAGER RESERVES
 THE RIGHT TO
 MAKE DESIGN
 CHANGES
 WITHOUT NOTICE.
 CALL HAGER
 ENGINEERING AT
 1-800-325-9995
 FOR THE LATEST
 REVISION DATE
 OF TEMPLATE.

	DRAWN	RCT	4/18/12
	ENG. APPR.	-	-
MATERIAL THERMOPLASTIC ELASTOMER	Q.A.		
FINISH -	TOLERANCES: FRACTIONAL: ±0.015" ANGULAR: MACH: ± 1° BEND: ±1° TWO PLACE DECIMAL: ±0.01" THREE PLACE DECIMAL: ±0.004"		
DO NOT SCALE DRAWING			

728		PRESS-ON WEATHERSTRIPPING	
SIZE A	DWG. NO. S-TW00145	REV.	
SCALE: 1:1	WEIGHT: 0.00	SHEET 1 OF 1	