

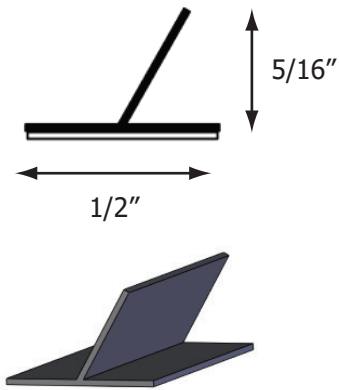

## 737 Press-On Weatherstripping Installation Instructions

I-TW00014 | R4, 07/14/23

- > Retards spread of flames, smoke, and hot gases
- > Excellent resistance to ozone, sunlight, and oxidation
- > Maintains excellent flexibility at low temperatures and resists high heat



### Finish

Charcoal (S)  White (W)

### Length

17' (5.182m)  18' (5.486m)  19' (5.791m)

20' (6.096m)  21' (6.40m)  22' (6.705m)

25' (7.62m)  260' (79.248m)  520' (158.496m)

### Silicone

Store weatherstrip in original packaging at ambient conditions 64°F (18°C) to 76°F (24°C).



Positive-Pressure-Tested Gasketing Materials for Fire Doors, complying with UL10C. Category J gaskets for use with Listed steel frames and/or Classified steel covered composite, hollow metal doors rated up to 3 hrs; wood and plastic covered composite doors rated up to 1-1/2 hrs; and wood core doors rated for 20 minutes.

**737 PRESS-ON WEATHERSTRIP**

Hager Companies  
139 Victor Street  
St. Louis, MO 63104



Incorrect surface preparation may result in separation of the 737 seal from the frame. This product should be used within 6 months of purchase. Before installing, thoroughly clean the door frame with the enclosed wipe, removing dust, grease, dirt, or other foreign materials. If packaged wipe is unavailable, the use of isopropyl alcohol is recommended. Cleansed area should be allowed to dry before application. NOTE: Mineral spirits or petroleum-based cleaning products should NOT be used.

**Instructions:**

1. Pre-cut the jamb and header pieces to fit before installation. Do not install as one continuous piece.
2. Remove protective backing, 18" to 24" at a time, while you position the gasketing--keeping adhesive free from foreign substances.
3. Apply to the frame in short sections by pressing firmly into place. Do not stretch product during installation. (If a pre-cut length is too long, stretching has occurred. Remove and reset.)
4. If error is made during initial application, resetting is possible.
5. Once installed, apply firm pressure along the entire surface of the product to ensure a secure bond.

**For best results:**

- Frame temperature during installation should be between 50°F (10°C) and 100°F (38°C)--ideally between 65°F (18°C) and 80°F (27°C).
- Paint on frame must be cured for 7 days. If paint is wet under the dry surface, it will cause adhesion problems. Avoid quick-dry primers that leave a powdery surface. If applying to a wood frame, the surface must be sealed prior to application of the press-on product.
- High-gloss painted surfaces may require roughening of the surface with a scotch brite pad or sandpaper for adhesive to properly bond. NOTE: Some compounds such as anti-bacterial, anti-fungal, or silicone additives in paint may prevent sufficient adhesion.
- Use very firm pressure when applying. This is one of the most important aspects to ensuring a secure bond.
- Check adhesion before leaving the jobsite overnight. If gasketing has separated from the frame, press again to put back in place. Complete curing reached in 24 hours. It may require replacement if dust has affected adhesive.

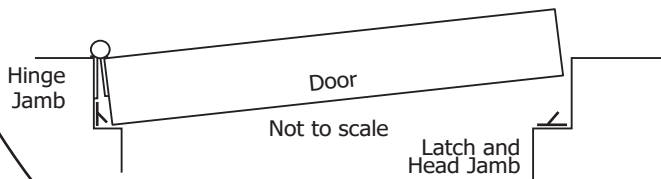

REV 4, 07/14/23  
66990007