

**CONTENTS**

1. HEADER & TRACK ASSEMBLY	1
2. END BRACKET FLANGED	1
3. END BRACKET PLAIN	1
4. FLOOR PLATE	2
5. SPLIT STUD	4
6. CARRIER (9606)	2
7. QUICK RELEASE PLATE (9610)	2
8. DOOR GUIDE SET (9883)	1
9. BUMPER KIT (9881)	1
10. #8 X 3/4" PPHS	1
11. #8 X 1" PPHS	8
12. #8 X 5/8" TPHS	2
13. PULL	1
(SOLD SEPERATLY)	

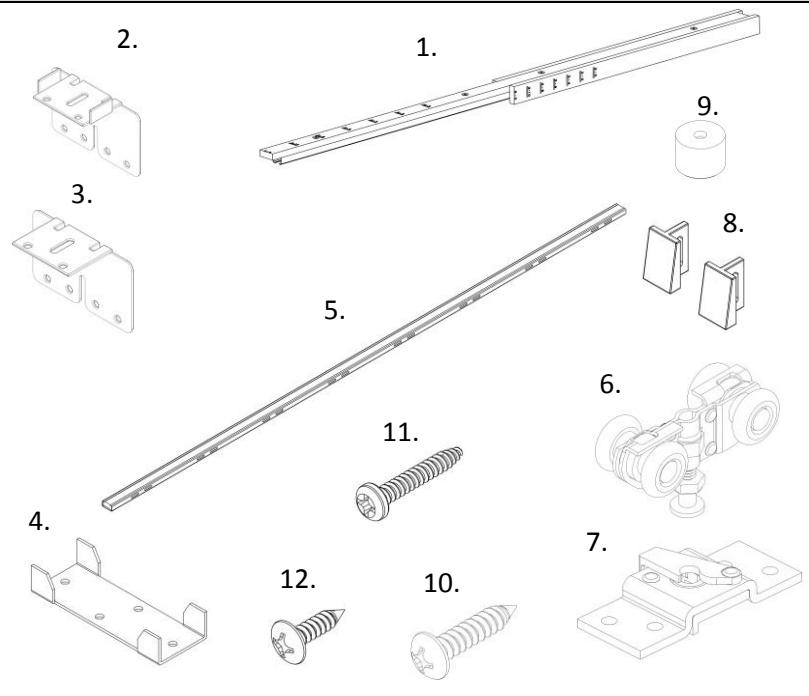

**1 PREPARE HEADER AND ROUGH OPENING**

**Opening Dimensions From Door Heights (Table 1)**

		Rough Opening Height	Bracket Nail Height	Part Number	Bottom Of Track to Floor
Door Height	6'-8" Door	84-1/2"	80-3/4"	9631	80-3/8"
	7'-0" Door	88-1/2"	84-3/4"	9630	84-3/8"
	8'-0" Door	100-1/2"	96-3/4"	9629	96-3/8"
	9'-0" Door	112-1/2"	108-3/4"	9628	108-3/8"

- Construct the rough opening by following the guidelines in the table above:
- The minimum rough opening height from the finished floor to the top of the door frame should be 84-1/2" for a 6'-8" door and adjust accordingly from Table 1 above for different door heights.
- The rough opening width should equal two times the door width plus 1" (25.4mm). For example, a 30" (76.2 cm) door multiplied by two equals 60" (152.4 cm) plus 1" equals 61" (154.94 cm) rough opening width. Refer to Table 2 on page 2 for all other door width dimensions.
- Next, plumb the rough studs and ensure that the floor is level.

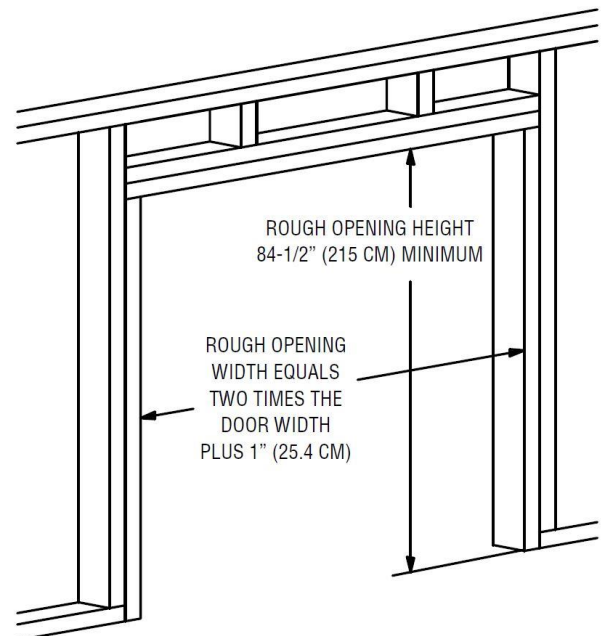

- Prepare the header and track assembly, note that the track in this kit will fit a 3'-0" (91.44 cm) door without modification, but it can easily be cut to accommodate any size door less than 3'-0" (91.44), as shown below using the dimensions from Table 2.

Opening Dimensions From Door Widths (Table 2)				
		Header Length	Nailing strip length	Rough Opening Width
Door Width (W)	3'-0"	72-5/8"	37"	73"
	2'-10"	68-5/8"	35"	69"
	2'-8"	64-5/8"	33"	65"
	2'-6"	60-5/8"	31"	61"
	2'-4"	56-5/8"	29"	57"
	2'-2"	52-5/8"	27"	53"
	2'-0"	48-5/8"	25"	49"
	Custom	$(2 \times W) + 5/8"$	$W + 1"$	$(2 \times W) + 1"$

(A) Cut the wood header at the appropriate stamped size mark. Cut the wood header only.

(B) Turn the header on its side to cut the nailing boards. Cut both nailing boards at the required marks, being careful not to cut the track.

(C) Turn the track assembly back over and cut the track 1-1/2" (38.1 mm) back from the end of wood header.

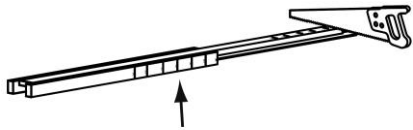

MARKINGS FOR STANDARD DOOR WIDTHS.

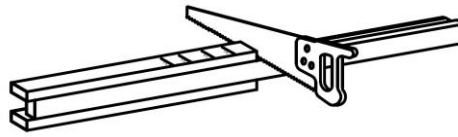

## 2 Mount Brackets

- Determine the height of the finished floor. Then mark each side of the rough opening the determined distance using the bracket nail height dimension from Table 1. For example, mark points 80-3/4" (205.1 cm) above the finished floor when using a door 6'-8" in height.

**Note: if measuring from a rough sub-floor, be sure to add the estimated thickness of the finished floor material and/or carpeting**

- Next, drive a flat-headed nail on the centerline of each framing stud at the appropriate height mark, until only 1/8" (3.17 mm) of the nail is left protruding. The slot in the end brackets will slide over these nails.

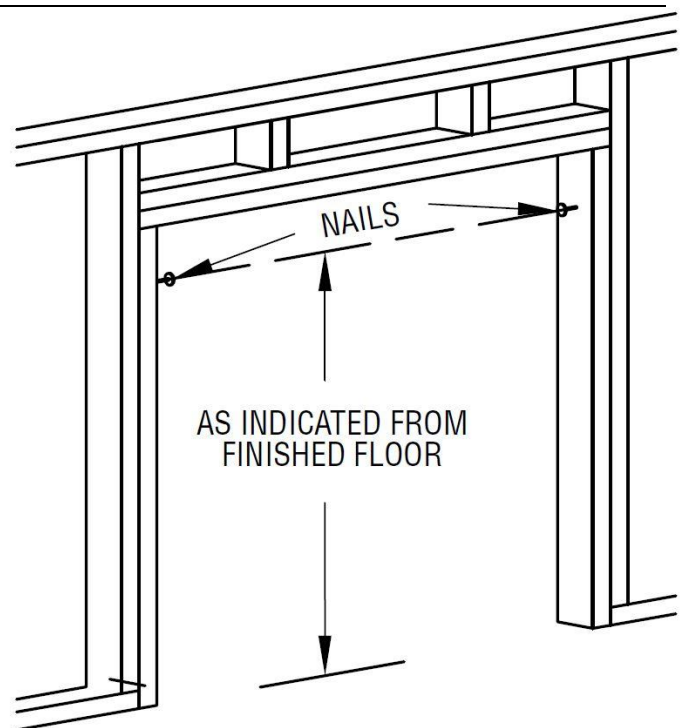

- Slide the slot in the pocket end bracket over the nail head. Level it. Seat the nail. Double check level, drive additional nails to secure. See pocket bracket figure to right.
- Next, mount the doorway end bracket to the jamb in the doorway. Level it and secure it with additional nail as before, see doorway bracket figure to the right.

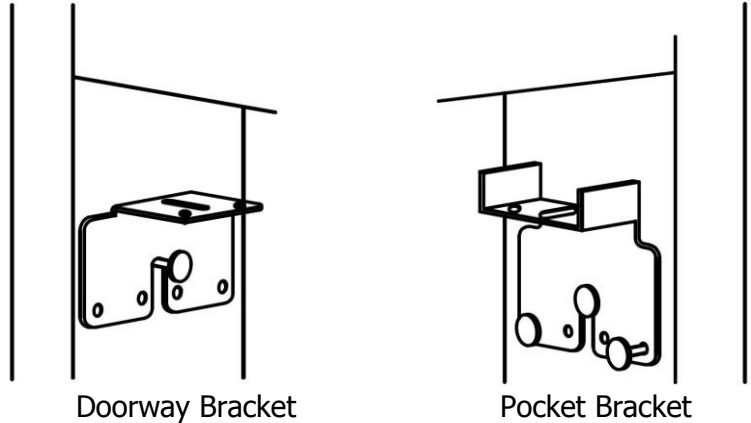

### 3 Mount Frame Hardware

- Draw two reference chalk lines on the floor, making sure they are even with the sides of the framing studs.
- Insert both carriers into the track **BEFORE** installing header assembly.
- Attach the header and track with the Nailing boards over your desired doorway. Set the header and track assembly on the attached end brackets with the screws provided, screw the end brackets to the header and track assembly in the pre-drilled holes in the header.
- Lay down the floor plates between the chalk lines, one approximately in the center of the opening and the other approximately halfway between it and the rough stud of the pocket side, **do NOT** nail them in place.
- Check the door thickness. When installed without modifications, this pocket door frame allows 2" (50.8 mm) of free space for the door between the split studs. A 1-3/8" (34.93 mm) door would leave 5/16" (7.94 mm) clearance on each side. A 1-3/4" (44.45 mm) door would leave 1/8" (3.18) clearance on each side.

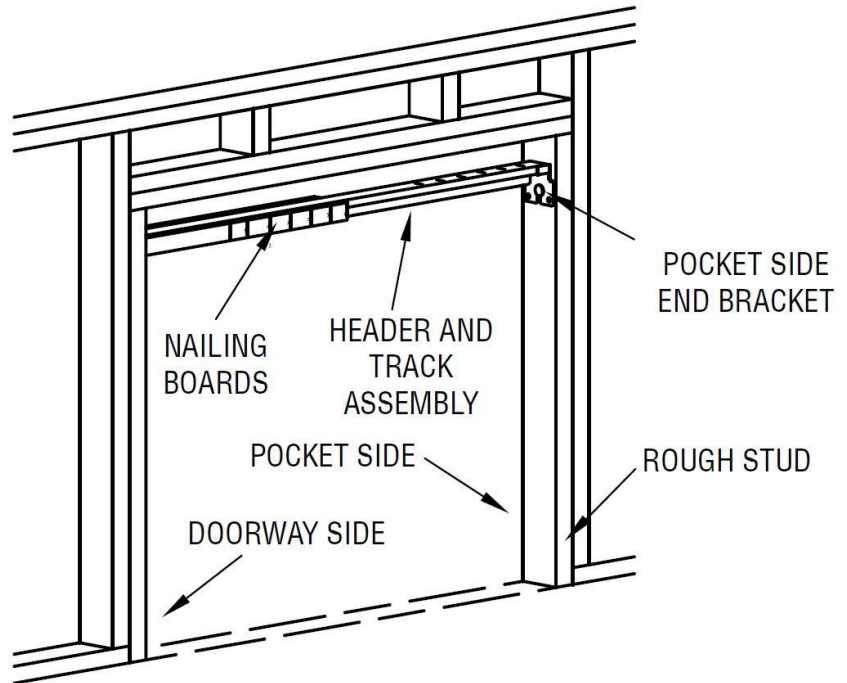

**Note: for additional clearance, floor plates may be cut and spread apart. Shims may also be inserted between header assembly and split studs. Or, you can use Hager's 9634 door adaptor kit (sold separately), which contains shims and wider floor plates for additional clearance with 1-3/4" thick doors.**

## 4 Install Split Studs

- Engage ends of split studs onto floor plates so that the slots on the backside are against the header. If the split studs must be shortened for shorter doors, determine which end of the stud has the slots close to the end and cut off the other end.

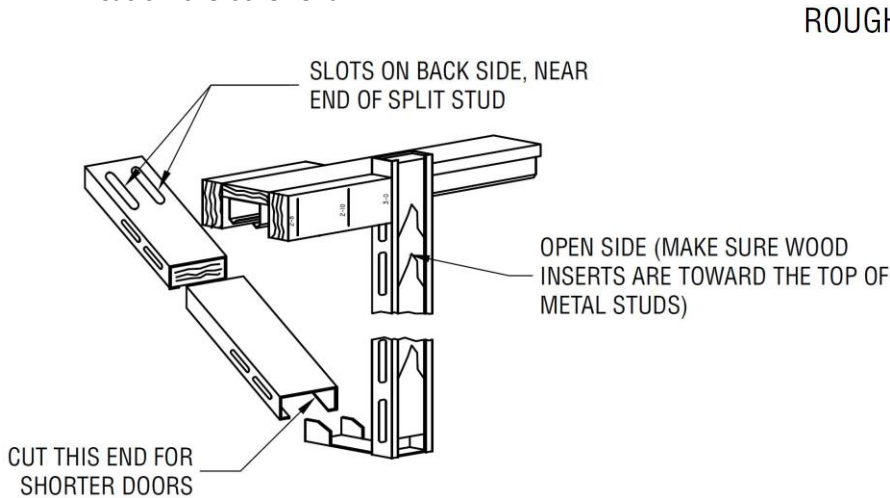

ROUGH HEADER

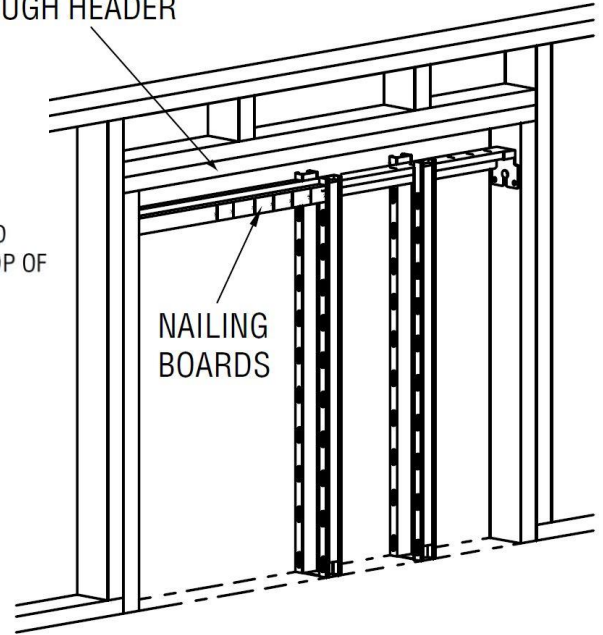

**Note: for best results, pre drill holes before screwing**

- Butt one pair of split studs against the header nailing boards and screw to header. Screw the other pair of split studs to the header midway between the first pair of split studs and the rough stud on the pocket side. Re-position the floor plates between the chalk lines. Plumb the split studs to make sure they are vertical and square. Screw the floor plates to the floor.

## 5 Mount Door Hardware

- Mount pocket door plate 1" from near edge to pocket door edge, mount opening plate 2-3/4" from near edge to opening door edge, secure bumper as close to dead center on pocket edge of door.

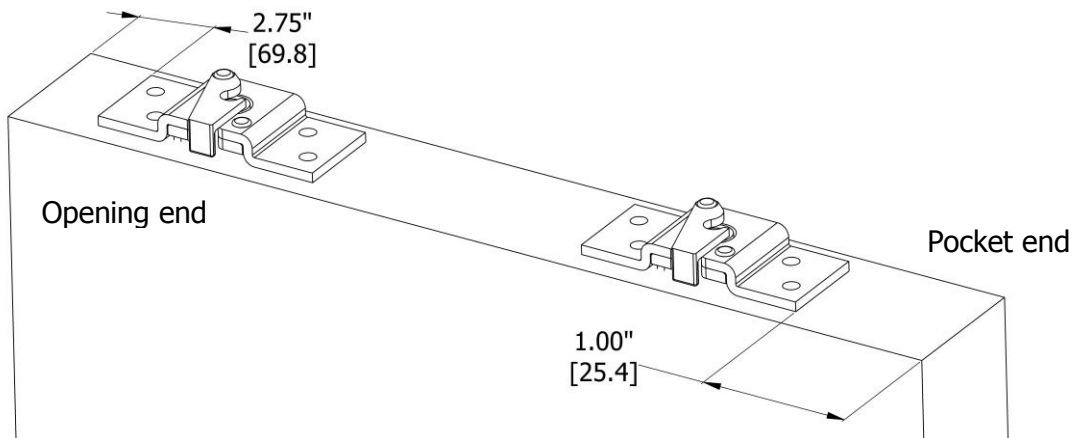

**Note: when installing bi-parting doors change Opening distance to 3-3/4" from edge of door.**

## 6 Hang Door

- Open quick release latches on bracket install door by sliding the door onto the carrier's screws and closing the latch, mounting rear edge first, then front edge.

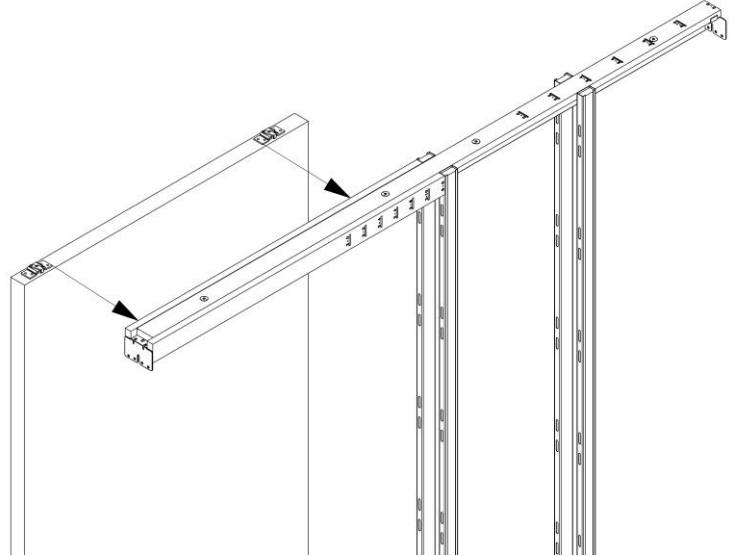

## 7 Finish Jambs & Trim

- Install the vertical jambs, butting them all the way up against the exposed wood of the nailing boards and butting them to the header assembly, as shown. Leave 1/8" minimum clearance on both sides of door.

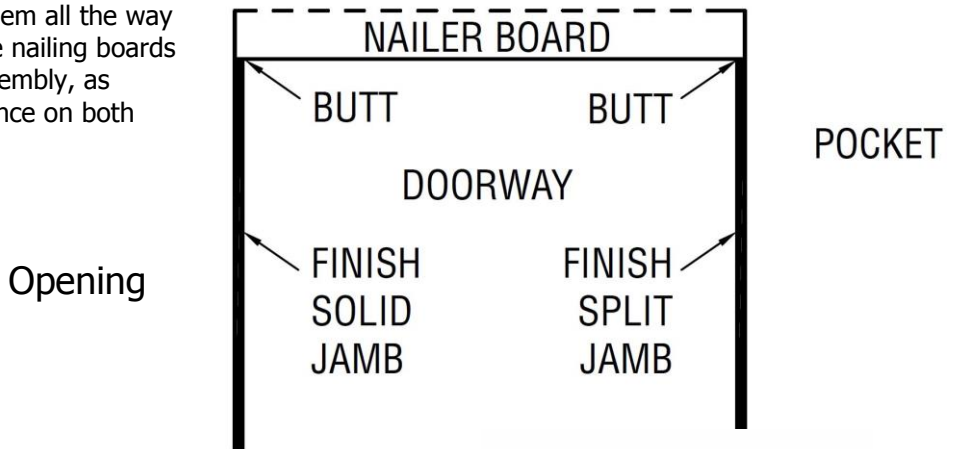

- After, using wrench provided adjust door hangers for height above the floor and to square door to solid jamb by turning the adjusting bolt on each hanger

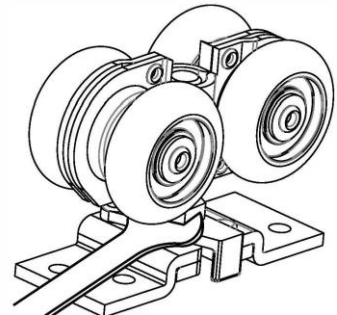



Install finish split header to the exposed wood on either side of the track. To allow for future door adjustment or removal, at least one finished split header should be attached with screws only; the one on your right hand overhead as you face the door in the pocket is recommended.

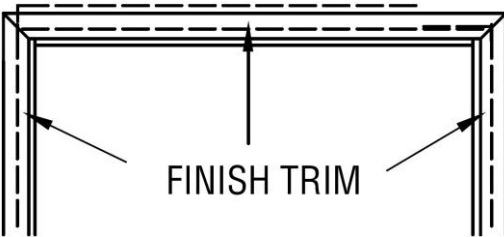

Install finish trim or casing. Fasten finish header trim to **EITHER** header **OR** wall, **NOT BOTH**, so the header can be removed later without damage.

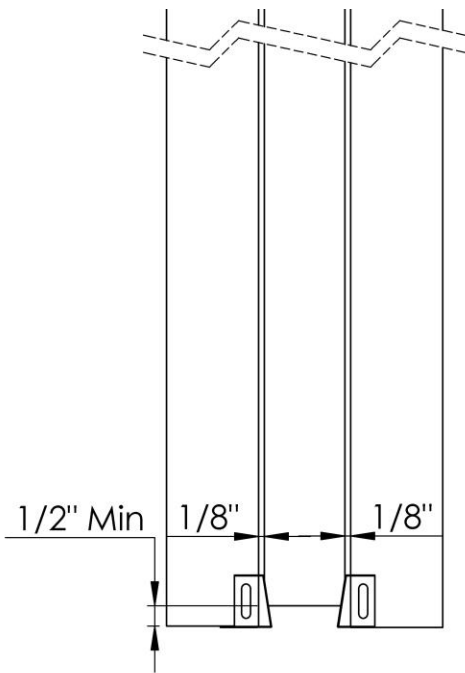

Install Door guides to finish split jamb and adjust to within 1/16" of door on either side